

# USER MANUAL

DAP-1522

VERSION 1.2



---

# Table of Contents

<b>Product Overview</b> .....	<b>4</b>	WLAN Partition .....	30
Package Contents .....	4	DHCP Server .....	31
System Requirements .....	4	DHCP Reservation .....	32
Introduction .....	5	QoS .....	33
Features .....	6	Traffic Manager .....	35
Hardware Overview .....	7	Add Traffic Manager Rule .....	36
Connections .....	7	Schedule .....	37
LEDs .....	8	Tools .....	38
<b>Installation</b> .....	<b>9</b>	Admin .....	38
Before you Begin .....	9	Time .....	39
Wireless Installation Considerations .....	10	System .....	40
<b>AP/Bridge/Auto Mode</b> .....	<b>11</b>	Language Pack .....	41
<b>Configuration for AP Mode</b> .....	<b>13</b>	Firmware .....	41
Web-based Configuration Utility .....	13	Status .....	43
Setup Wizard .....	14	Device Info .....	43
Wireless Setup Wizard .....	15	Wireless .....	44
Add Wireless Device With WPS .....	22	Logs .....	45
Manual Configuration .....	24	Statistics .....	46
Wireless Settings .....	24	Help .....	47
Network Settings .....	26	<b>Configuration for Bridge Mode</b> .....	<b>48</b>
DHCP .....	26	Web-based Configuration Utility .....	48
Static IP .....	27	Setup Wizard .....	49
Advanced .....	28	Wireless .....	57
MAC Address Filter .....	28	Wireless MAC Cloning .....	58
Advanced Wireless .....	29	Network Settings .....	59
		Static .....	59

DHCP .....	60	<b>Connect to a Wireless Network.....</b>	<b>85</b>
Advanced.....	61	Using Windows® Vista .....	85
Advanced Wireless .....	61	Configure WEP .....	87
QoS.....	62	Configure WPA-PSK .....	88
Schedule .....	64	<b>Troubleshooting .....</b>	<b>89</b>
Tools .....	65	<b>Wireless Basics .....</b>	<b>93</b>
Admin.....	65	What is Wireless? .....	94
Time.....	66	Tips.....	96
System.....	67	Wireless Modes .....	97
Language Pack.....	68	<b>Networking Basics .....</b>	<b>98</b>
Firmware .....	68	Check your IP address .....	98
Status .....	70	Statically Assign an IP address .....	99
Device Info .....	70	<b>Technical Specifications.....</b>	<b>100</b>
Logs .....	71		
Help .....	72		
<b>Wireless Security.....</b>	<b>73</b>		
What is WEP? .....	73		
What is WPA? .....	74		
Configure WEP in AP Mode .....	75		
Configure WPA-Personal (AP Mode) .....	76		
Configure WPA-Enterprise (AP Mode) .....	77		
Configure WEP (Bridge Mode) .....	78		
Configure WPA-Personal (Bridge Mode).....	79		
<b>Connect to a Wireless Network.....</b>	<b>80</b>		
Using Windows® XP.....	80		
Configure WEP .....	81		
Configure WPA-PSK .....	83		

## Package Contents

- D-Link DAP-1522 Xtreme N Duo Wireless Bridge
- Power Adapter
- CAT5 Ethernet Cable
- Rubber Feet
- CD-ROM with User Manual



**Note:** Using a power supply with a different voltage than the one included with the DAP-1522 will cause damage and void the warranty for this product.

## System Requirements

- Computers with Windows®, Macintosh®, or Linux-based operating systems with an installed Ethernet adapter
- Internet Explorer Version 7.0, Mozilla or Firefox 3.0 and above (for configuration)

# Introduction

## **TOTAL PERFORMANCE**

Combines award winning access point features and Draft 802.11n wireless technology to provide the best wireless performance.

## **TOTAL SECURITY**

The most complete set of security features including WPA2 and MAC Address Control to protect your network against outside intruders.

## **TOTAL COVERAGE**

Provides greater wireless signal rates even at farther distances for best-in-class Whole Home Coverage.

## **ULTIMATE PERFORMANCE**

The D-Link Xtreme N™ Duo Wireless Bridge (DAP-1522) is a draft 802.11n compliant device that delivers real world performance of up to 650% faster than an 802.11g wireless connection (also faster than a 100Mbps wired Ethernet connection). Create a secure wireless network to share photos, files, music, video, printers, and network storage throughout your home. Connect the Xtreme N™ Duo Wireless Bridge to router and share your high-speed Internet access with everyone on the network. In addition, this Wireless Bridge includes a Quality of Service (QoS) engine that keeps digital phone calls (VoIP) and online gaming smooth and responsive, providing a better Internet experience.

## **EXTENDED WHOLE HOME COVERAGE**

Powered by Xtreme N™ Duo technology, this high performance Wireless Bridge provides superior Whole Home Coverage while reducing dead spots. The Xtreme N™ Duo Wireless Bridge is designed for use in bigger homes and for users who demand higher performance networking. Add an Xtreme N™ Duo notebook or desktop adapter and stay connected to your network from virtually anywhere in your home.

## **TOTAL NETWORK SECURITY**

The Xtreme N™ Duo Wireless Bridge supports all of the latest wireless security features to prevent unauthorized access, be it from over the wireless network or from the Internet. Support for WPA and WEP standards ensure that you'll be able to use the best possible encryption method, regardless of your client devices.

\* Maximum wireless signal rate derived from IEEE Standard 802.11g, 802.11a and Draft 802.11n specifications. Actual data throughput will vary. Network conditions and environmental factors, including volume of network traffic, building materials and construction, and network overhead, lower actual data throughput rate. Environmental conditions will adversely affect wireless signal range.

# Features

- **Faster Wireless Networking** - The DAP-1522 provides up to 300Mbps\* wireless connection with other 802.11n wireless clients. This capability allows users to participate in real-time activities online, such as video streaming, online gaming, and real-time audio. The performance of this 802.11n wireless access point gives you the freedom of wireless networking at speeds 650% faster than 802.11g.
- **Compatible with 802.11a, 802.11b, and 802.11g Devices** - The DAP-1522 is still fully compatible with the IEEE 802.11a/b/g standard, so it can connect with existing 802.11a/b/g PCI, USB, and Cardbus adapters.
- **Advanced Firewall Features** - The Web-based user interface displays advanced network management features including Content Filtering, which allows easily applied content filtering based on MAC Address.
- **WPS PBC-** (Wi-Fi Protected Setup Push Button Configuration) Push Button Configuration is a button that can be pressed to add the device to an existing network or to create a new network. A virtual button can be used on the utility while a physical button is placed on the side of the device.  
This easy setup method allows you to form a secured wireless link between the DAP-1522 and another WPS enabled device. A PC is no longer needed to log into the Web-based interface.
- **WPS PIN** - (Wi-Fi Protected Setup Personal Identification Number ) A PIN is a unique number that can be used to add the access point to an existing network or to create a new network. The default PIN may be printed on the bottom of the access point. For extra security, a new PIN can be generated. You can restore the default PIN at any time. Only the Administrator (“admin” account) can change or reset the PIN.
- **User-friendly Setup Wizard** - Through its easy-to-use Web-based user interface, the DAP-1522 lets you control what information is accessible to those on the wireless network, whether from the Internet or from your company’s server. Configure your access point to your specific settings within minutes.

# Hardware Overview

## Connections

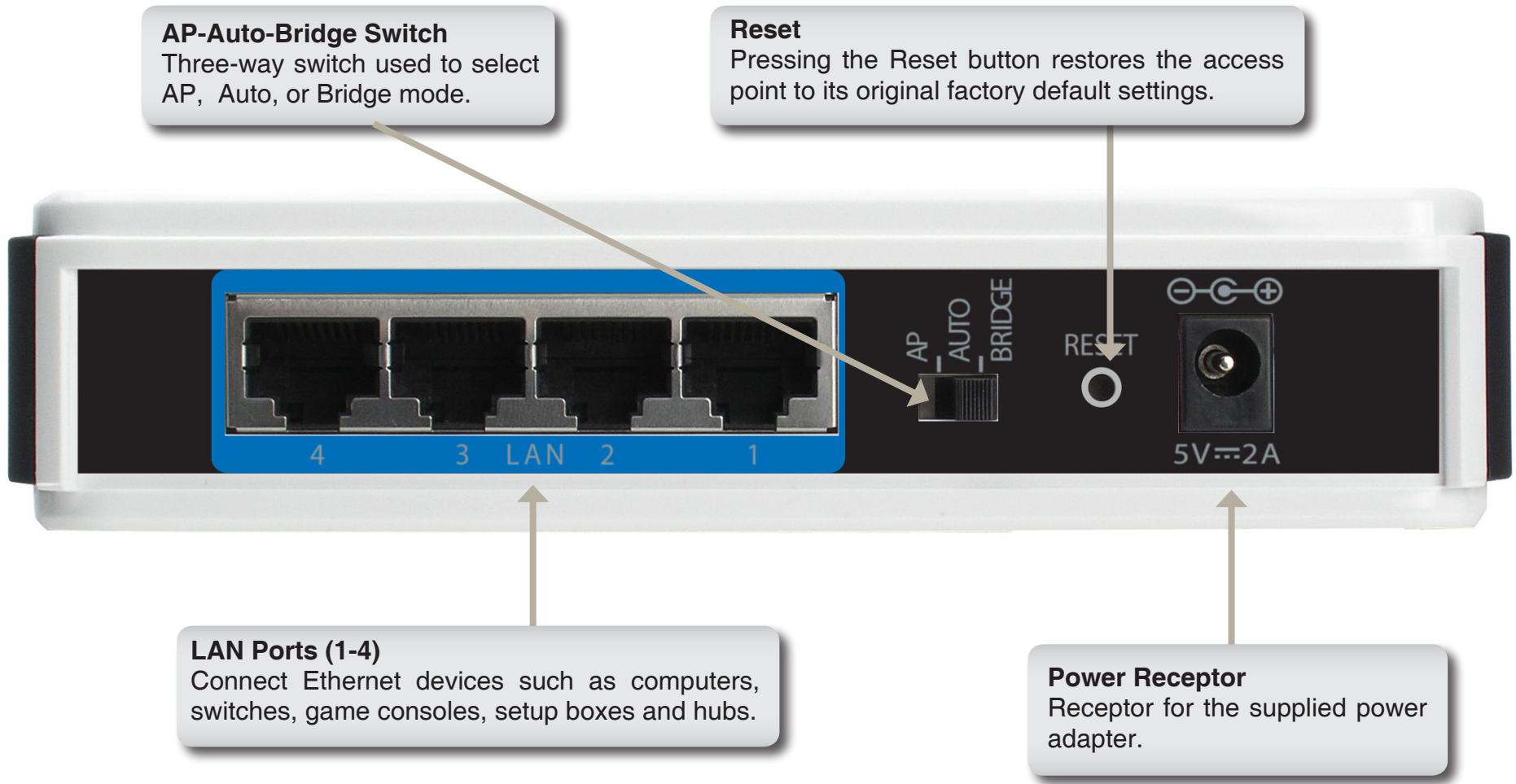

# Hardware Overview

## LEDs

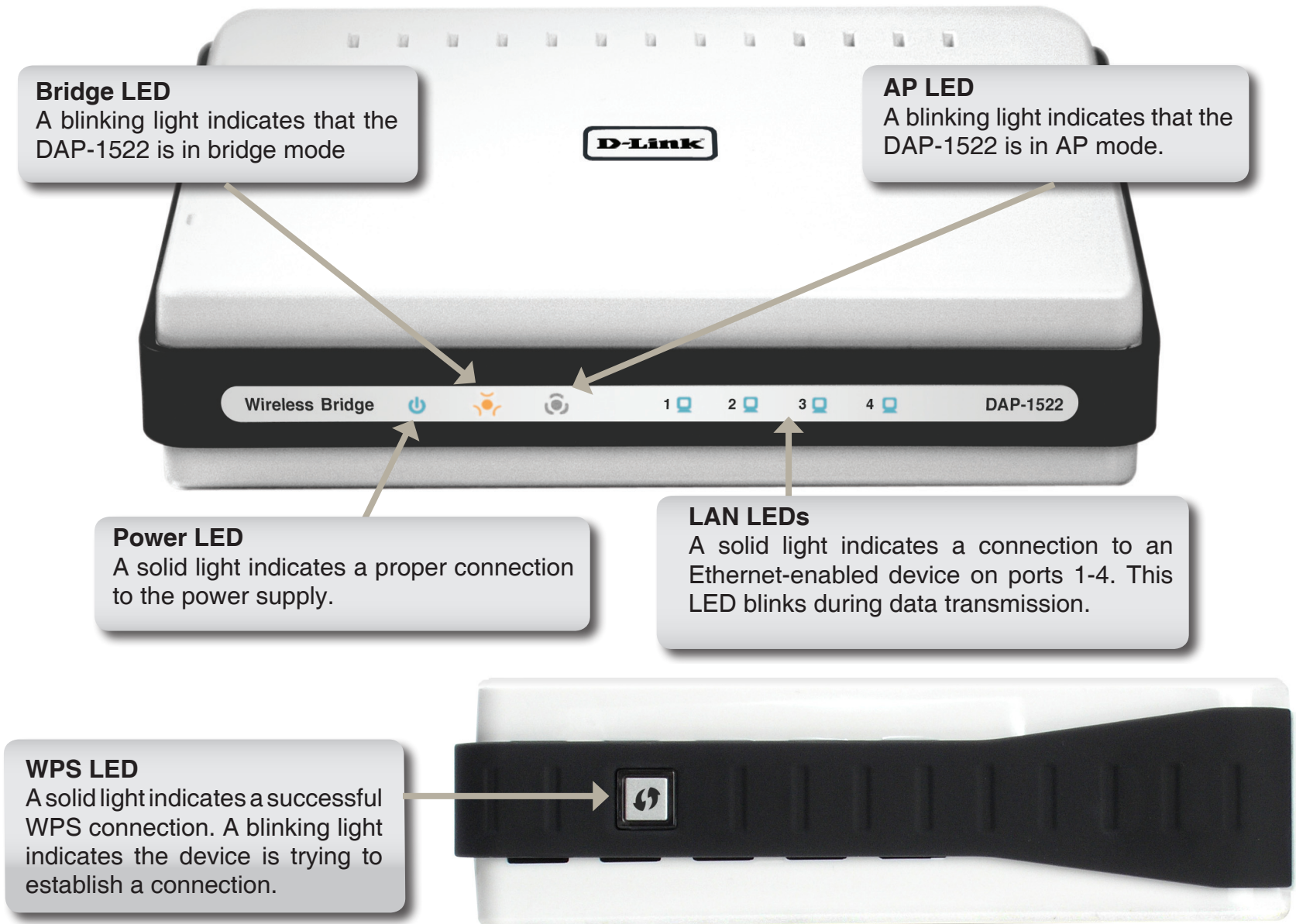



# Installation

This section will walk you through the installation process. Placement of the DAP-1522 is very important. Do not place the DAP-1522 in an enclosed area such as a closet, cabinet, or in the attic or garage.

## Before you Begin

Please configure the Wireless Bridge with the computer that was last connected directly to your modem. Also, you can only use the Ethernet port on your modem. If you were using the USB connection before using the Wireless Bridge, then you must turn off your modem, disconnect the USB cable and connect an Ethernet cable to the Internet port on the Wireless Bridge, and then turn the modem back on. In some cases, you may need to call your ISP to change connection types (USB to Ethernet).

If you have DSL and are connecting via PPPoE, make sure you disable or uninstall any PPPoE software such as WinPoet, Broadjump, or Enternet 300 from your computer or you will not be able to connect to the Internet.

# Wireless Installation Considerations

The D-Link wireless access point lets you access your network using a wireless connection from virtually anywhere within the operating range of your wireless network. Keep in mind, however, that the number, thickness and location of walls, ceilings, or other objects that the wireless signals must pass through, may limit the range. Typical ranges vary depending on the types of materials and background RF (radio frequency) noise in your home or business. The key to maximizing wireless range is to follow these basic guidelines:

1. Keep the number of walls and ceilings between the D-Link access point and other network devices to a minimum. Each wall or ceiling can reduce your adapter's range from 3-90 feet (1-30 meters.) Position your devices so that the number of walls or ceilings is minimized.
2. Be aware of the direct line between network devices. A wall that is 1.5 feet thick (.5 meters), at a 45-degree angle appears to be almost 3 feet (1 meter) thick. At a 2-degree angle it looks over 42 feet (14 meters) thick! Position devices so that the signal will travel straight through a wall or ceiling (instead of at an angle) for better reception.
3. Building Materials make a difference. A solid metal door or aluminum studs may have a negative effect on range. Try to position access points, wireless access points, and computers so that the signal passes through drywall or open doorways. Materials and objects such as glass, steel, metal, walls with insulation, water (fish tanks), mirrors, file cabinets, brick, and concrete will degrade your wireless signal.
4. Keep your product away (at least 3-6 feet or 1-2 meters) from electrical devices or appliances that generate RF noise.
5. If you are using 2.4GHz cordless phones or X-10 (wireless products such as ceiling fans, lights, and home security systems), your wireless connection may degrade dramatically or drop completely. Make sure your 2.4GHz phone base is as far away from your wireless devices as possible. The base transmits a signal even if the phone is not in use.

# AP/Bridge/Auto Mode

Depending on how you want to use your DAP-1522 will determine which mode you use. This section will help you figure out which setting works with your setup.

## AP Mode

If you already have a wired or wireless router, and want to add a MediaBand (5GHz wireless), to your network, you will need to move the switch on the back panel of the DAP-1522 to “AP”.

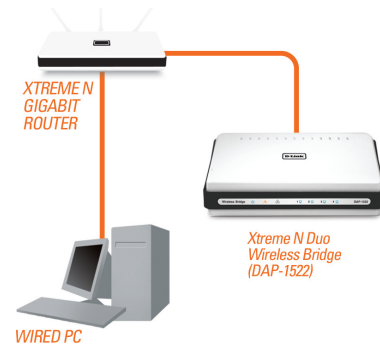

## Bridge Mode

If you want to wirelessly connect multiple Ethernet enabled devices such as game consoles, media players, or network attached storage devices you will need to move the switch on the back panel of the DAP-1522 to “Bridge”.

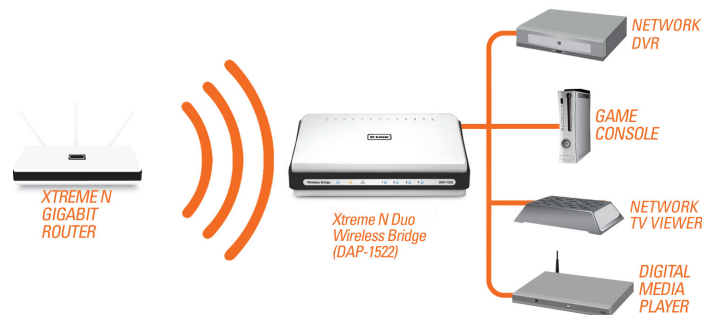

## Auto Mode

If the switch on the back panel of the DAP-1522 is set to “Auto”, the device will wait for 30 seconds, looking for a DHCP server from the ethernet ports. If an IP address is assigned, it will automatically shift to AP mode. If an IP address is not assigned from a DHCP server, the DAP-1522 will automatically shift to Bridge mode.

## Create a Full MediaBand (5GHz wireless) Network

If you have two DAP-1522 devices and want to create a wireless network with full MediaBand technology you will need to connect one Wireless Bridge to your router and move the switch on the back panel to “AP”. The second Wireless Bridge will need to be placed next to your Ethernet-enabled devices and you will need to move the switch on the back panel to “Bridge”.

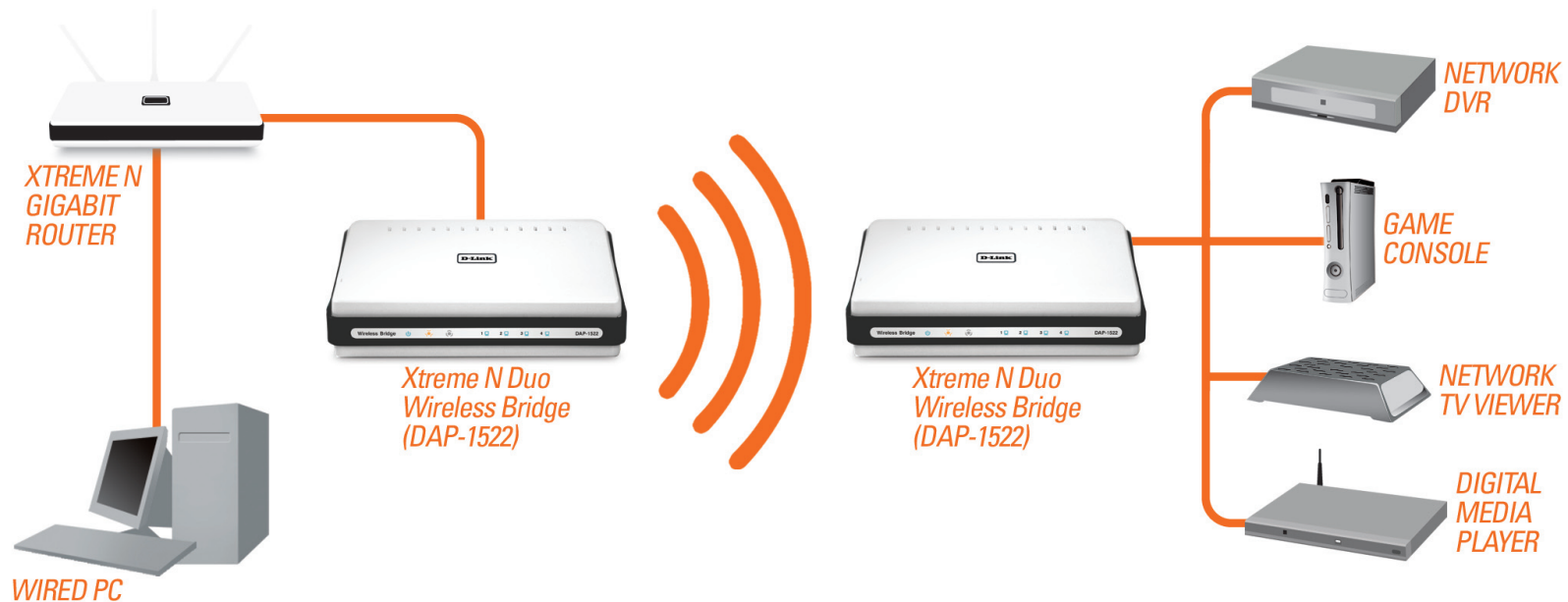

# Configuration for AP Mode

This section will show you how to configure your new D-Link wireless access point using the web-based configuration utility.

## Web-based Configuration Utility

To access the configuration utility, open a web browser such as Internet Explorer and enter dlinkap or 192.168.0.50 in the address field.

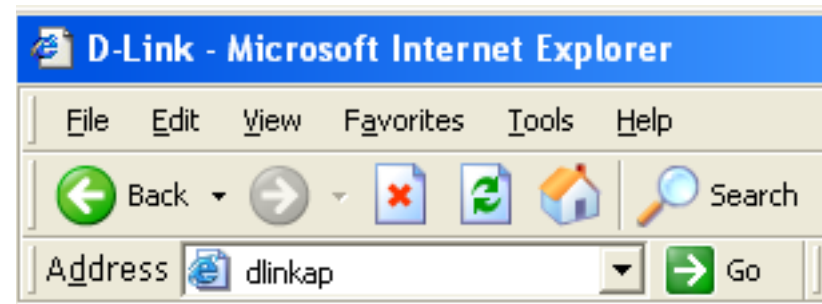

Select **Admin** from the drop-down menu and then enter your password. Leave the password blank by default.

If you get a Page Cannot be Displayed error, please refer to the Troubleshooting section for assistance.

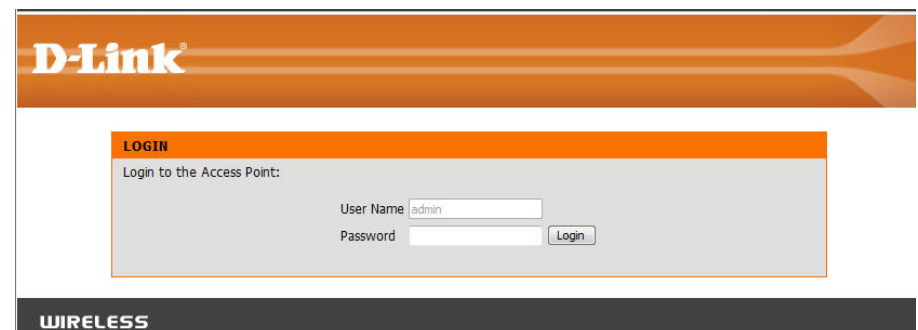

# Setup Wizard

Click **Launch Wireless Setup Wizard** to quickly configure your access point.

To set up your wireless network, click **Add Wireless Device With WPS** and skip to page 22.

If you want to enter your settings without running the wizard, click **Manual Wireless Network Setup** and skip to page 24.

The screenshot displays the D-Link DAP-1522 web interface. At the top, the D-Link logo is visible. Below it, a navigation bar includes tabs for SETUP, ADVANCED, MAINTENANCE, STATUS, and HELP. The main content area is titled 'WIRELESS SETTINGS' and contains three sections:

- WIRELESS SETTINGS**: A header section with a description of web-based wizards and a reference to the Quick Installation Guide.
- WIRELESS CONNECTION SETUP WIZARD**: A section with a description of the wizard and a button labeled 'Launch Wireless Setup Wizard'. A red note states: 'Note: Some changes made using this Setup Wizard may require you to change some settings on your wireless client adapters so they can still connect to the D-Link Access Point.'
- MANUAL WIRELESS NETWORK SETUP**: A section with a description of manual configuration and a button labeled 'Manual Wireless Network Setup'.
- ADD WIRELESS DEVICE WITH WPS (WIFI PROTECTED SETUP) WIZARD**: A section with a description of the WPS wizard and a button labeled 'Add Wireless Device With WPS'.

On the right side, a 'Helpful Hints..' section provides additional guidance for users with existing networks, new users, and advanced users. A 'More...' link is also present at the bottom of the hints section.

# Wireless Setup Wizard

This Wizard is designed to assist you in connecting your wireless device to your access point. It will guide you through step-by-step instructions on how to get your wireless device connected.

Enter the Device Name of the AP and click **Next** to continue. It is recommended to change the Device Name if there is more than one D-Link device within the subnet.



The screenshot shows the 'SET YOUR DEVICE NAME' step of the D-Link Wireless Setup Wizard. The page has an orange header with the D-Link logo. Below the header, there is a white box with an orange border containing the title 'SET YOUR DEVICE NAME' and instructions: 'Enter the Device Name of the AP. Recommend to change the Device Name if there're more than one D-Link devices within the subnet. Click **Next** to continue.' A text input field labeled 'Device Name (NetBIOS Name)' contains the text 'dlinkap'. Below the input field are two buttons: 'Next' and 'Exit'. At the bottom of the page, there is a dark grey bar with the word 'WIRELESS' in white capital letters.

If you want to change the admin account password, enter a new password and click **Next**.

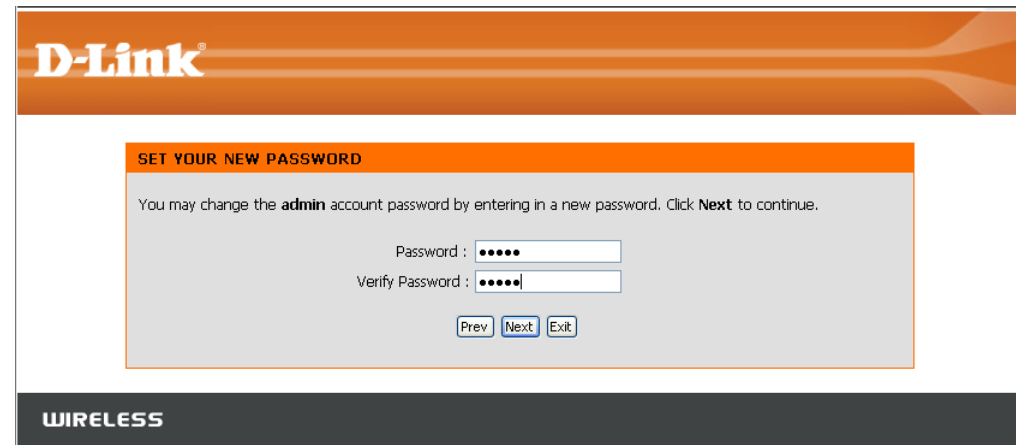

The screenshot shows the 'SET YOUR NEW PASSWORD' step of the D-Link Wireless Setup Wizard. The page has an orange header with the D-Link logo. Below the header, there is a white box with an orange border containing the title 'SET YOUR NEW PASSWORD' and instructions: 'You may change the **admin** account password by entering in a new password. Click **Next** to continue.' There are two password input fields: 'Password :' and 'Verify Password :', both containing masked characters (dots). Below the input fields are three buttons: 'Prev', 'Next', and 'Exit'. At the bottom of the page, there is a dark grey bar with the word 'WIRELESS' in white capital letters.

Select Auto as the configuration method only if your wireless device supports Wi-Fi Protected Setup.

Skip to page 17 for Manual configuration.

Click **Next** to continue.

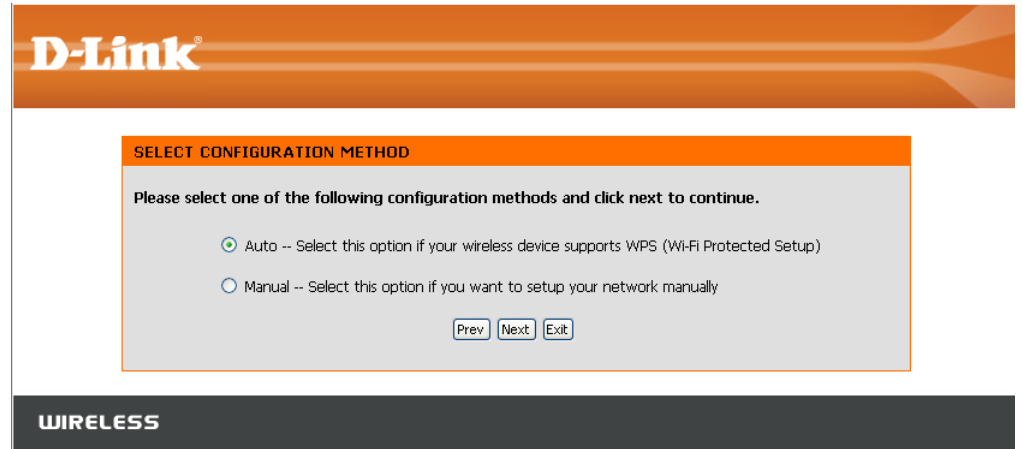

Click **Save** to save your network settings.

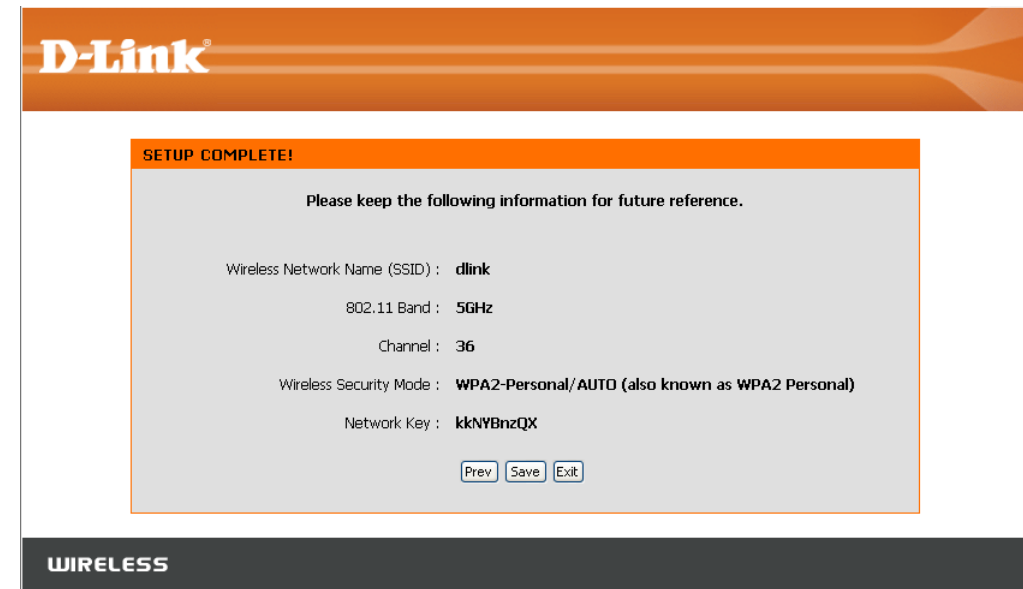



The following screen opens to indicate that you have successfully saved your new settings.

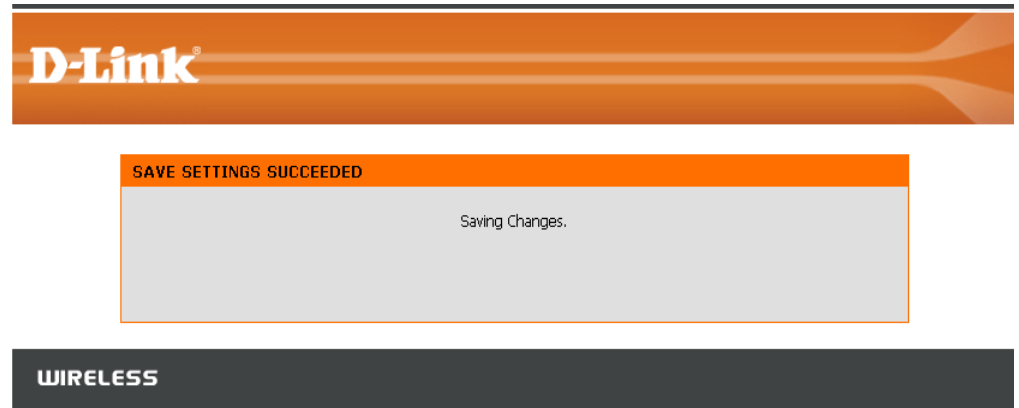

Select **Manual** as the configuration method to set up your network manually.

Click **Next** to continue.



Enter a network name and select Automatically assign a network key.

To Manually assign a network key, skip to page 19.

Click **Next** to continue.

If you choose WPA-PSK encryption, the following screen will show you your Network Key to enter on your wireless clients.

Click **Save** to finish the Setup Wizard.



**WELCOME TO THE D-LINK WIRELESS SETUP WIZARD**

Give your network a name, using up to 32 characters.

Network Name (SSID) :

802.11 Band  2.4GHz  5GHz

Channel

Auto Channel Scan

Automatically assign a network key (Recommended)  
To prevent outsiders from accessing your network, the AP will automatically assign a security key (also called WEP or WPA key) to your network.

Manually assign a network key  
Use this option if you prefer to create your own key.

Use WPA encryption instead of WEP (WPA is stronger than WEP and all D-Link wireless client adapters support WPA).



**SETUP COMPLETE!**

Please keep the following information for future reference.

Wireless Network Name (SSID) : **dlink**

802.11 Band : **5GHz**

Channel : **Auto Channel Scan**

Wireless Security Mode : **WPA-PSK**

Network Key : **7ZdtBzW3**



If you choose WEP encryption, the following screen will show you your Network Key to enter on your wireless clients.

Click **Save** to finish the Setup Wizard.

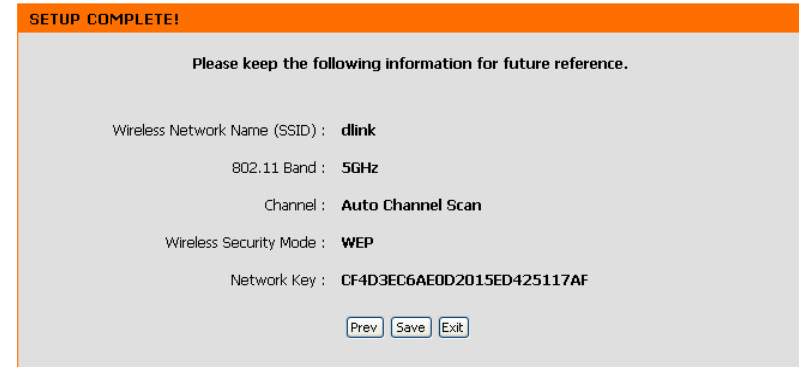

Choose Manually assign a network key to create your own key.

Click **Next** to continue.

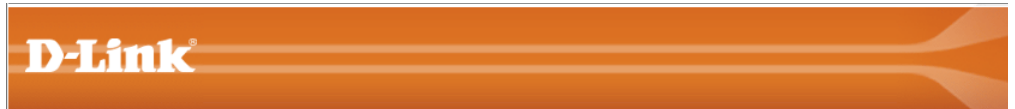

For WPA encryption, enter a Network Key between 8 and 63 characters long or enter exactly 64 characters using 0-9 and A-F.

Click **Next** to continue.

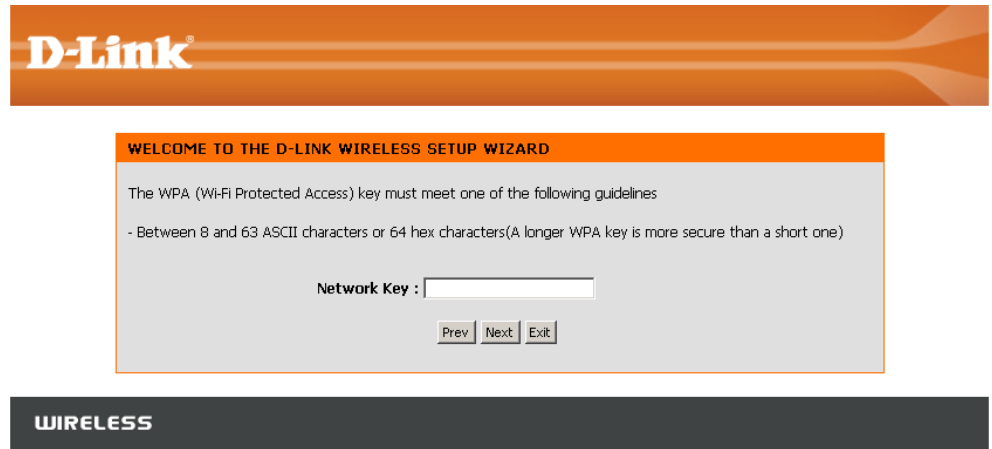

If you select WPA encryption, the following screen will show you your network key to enter on your wireless clients.

Click **Save** to finish the Setup Wizard.

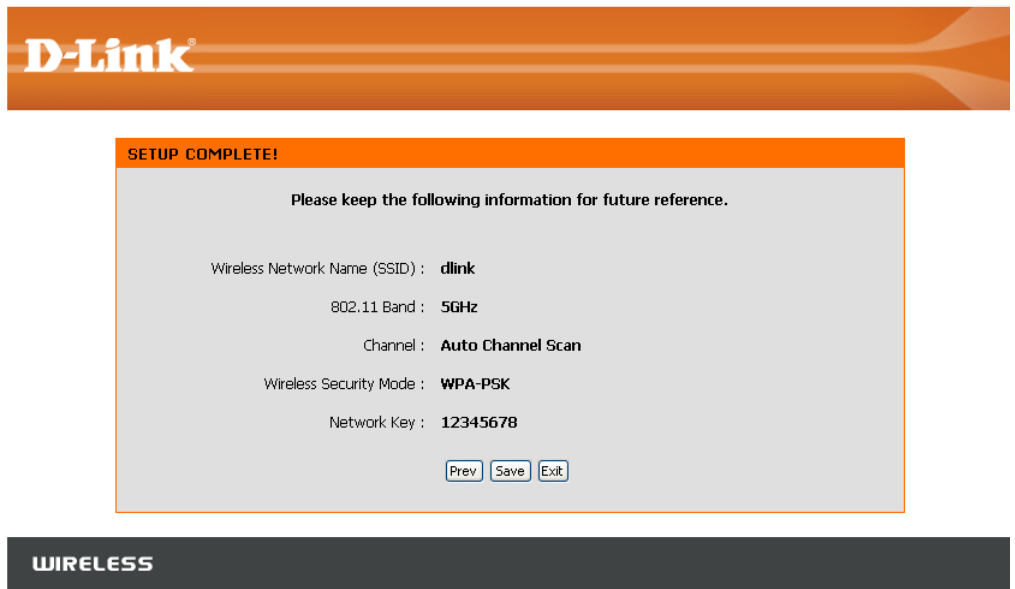

For **WEP** encryption, enter a Network Key exactly 5 or 13 characters long or exactly 10 or 26 characters using 0-9 and A-F.

Click **Next** to continue.

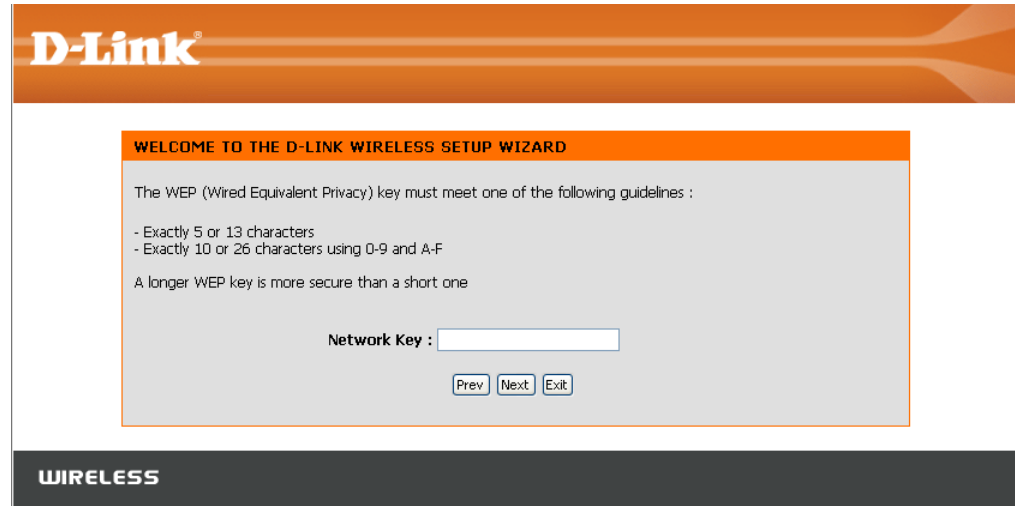

If you select **WEP** encryption, the following screen will show you your network key to enter on your wireless clients.

Click **Save** to finish the Setup Wizard.

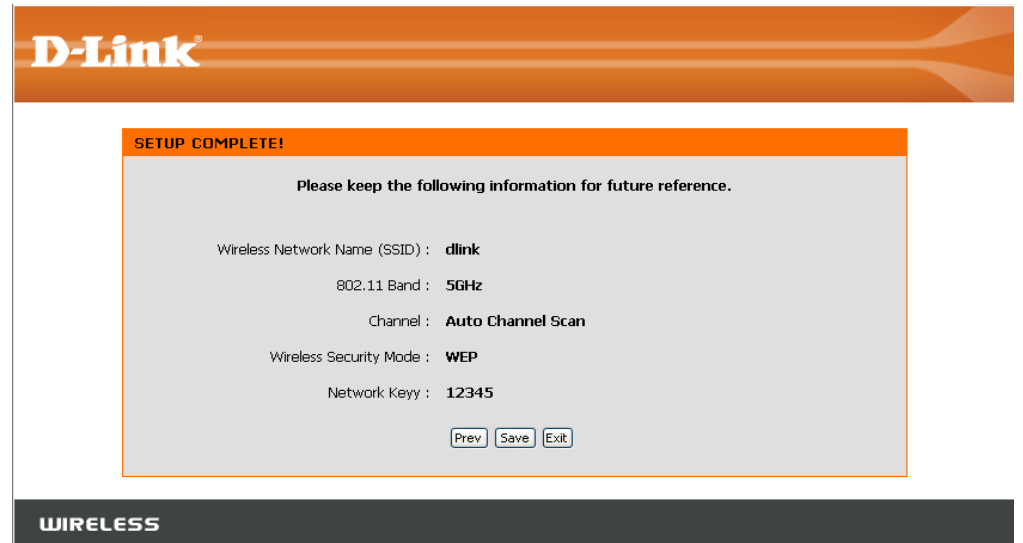

# Add Wireless Device With WPS

This Wizard is designed to assist you in your wireless network setup. It will guide you through step-by-step instructions on how to set up your wireless network and how to make it secure.

Select **PIN** to use your **PIN** number from your wireless device to connect to your network.

For **PBC** configuration, skip to page 23.

Click **Connect** to continue.

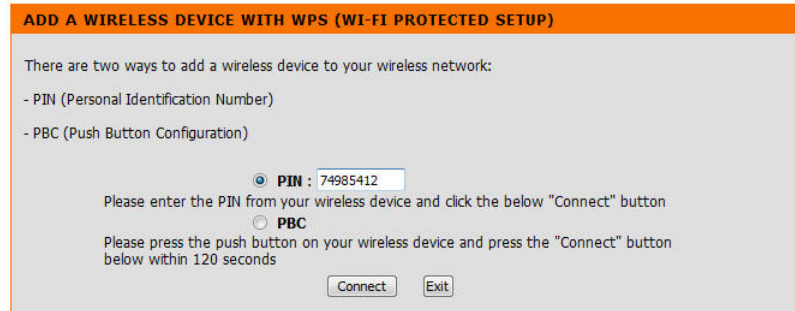

Start **WPS** on the wireless device you are adding to you wireless network to complete the setup.

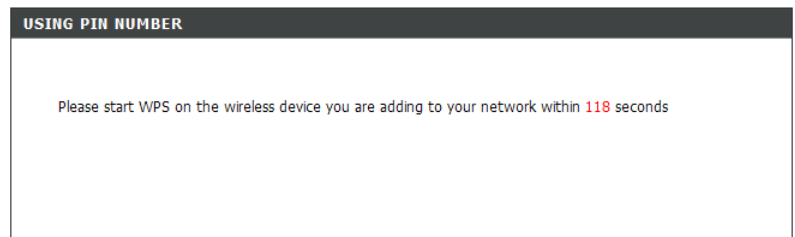

Select **PBC** to use the Push Button Configuration in order to connect to your network.

Click **Connect** to continue.



**ADD WIRELESS DEVICE WITH WPS (WI-FI PROTECTED SETUP)**

There are two ways to add wireless device to your wireless network:

- PIN (Personal Identification Number)
- PBC (Push Button Configuration)

PIN :

Please enter the PIN from your wireless device and click the below "Connect" button

PBC

Please press the push button on your wireless device and press the "Connect" button below within 120 seconds



Press down the **Push Button** on the wireless device that you are adding to your network to complete the setup.

Product Page : DAP-1522 Firmware Version : 1.00



**VIRTUAL PUSH BUTTON**

Please press down the Push Button (physical or virtual) on the wireless device you are adding to your wireless network within **116** seconds ...



# Manual Configuration

## Wireless Settings

**Wireless Mode:** The current wireless mode is set to Access Point, it will create a wireless infrastructure network.

**Enable Wireless:** Check the box to enable the wireless function. If you do not want to use wireless, uncheck the box to disable all the wireless functions.

**Wireless Network Name:** When you are browsing for available wireless networks, this is the name that will appear in the list (unless Visibility Status is set to Invisible, see below). This name is also referred to as the SSID. For security purposes, it is highly recommended to change from the pre-configured network name.

**802.11 Band:** Operating frequency band. Choose 2.4GHz for visibility to legacy devices and for longer range. Choose 5GHz for least interference.

**802.11 Mode:** If you choose 2.4GHz band, then select one of the following:

**Mixed 802.11n, 802.11g and 802.11b** - Select if you are using a mix of 802.11n, 11g, and 11b wireless clients.

**802.11b Only** - Select if you are only using 802.11b wireless clients.

**802.11g Only** - Select if you are only using 802.11g wireless clients.

**802.11n Only** - Select if you are only using 802.11n wireless clients.

**Mixed 802.11g and 802.11b** - Select if you are using a mix of 802.11g and 11b wireless clients.

**Mixed 802.11n and 802.11g** - Select if you are using a mix of 802.11n and 11g wireless clients.

If you choose 5GHz band, then select either **802.11a Only**, **802.11n Only**, or **Mixed 802.11n and 802.11a**.

The screenshot shows the D-Link DAP-1522 web interface. The top navigation bar includes tabs for SETUP, ADVANCED, MAINTENANCE, STATUS, and HELP. The current page is 'WIRELESS NETWORK' under the 'ADVANCED' tab. The page is divided into several sections:

- WIRELESS NETWORK:** Contains a message: "Use this section to configure the wireless settings for your access point. Please note that changes made on this section may also need to be duplicated on your Wireless Client." Below this are 'Save Settings' and 'Don't Save Settings' buttons.
- WIRELESS NETWORK SETTINGS:** Contains the following settings:
  - Wireless Mode: Access Point
  - Enable Wireless:
  - Wireless Network Name: dlink (Also called the SSID)
  - 802.11 Band:  2.4GHz  5GHz
  - 802.11 Mode: Mixed 802.11n and 802.11a
  - Enable Auto Channel Scan:
  - Wireless Channel: 36
  - Transmission Rate: Best(automatic) (Mbit/s)
  - Channel Width: 20 MHz
  - Visibility Status:  Visible  Invisible
- WIRELESS SECURITY MODE:** Contains:
  - Security Mode: Disable Wireless Security (not recommended)
- WI-FI PROTECTED SETUP (ALSO CALLED WCN 2.0 IN WINDOWS VISTA):** Contains:
  - Enable:
  - Lock Wireless Security Settings:
  - Current PIN: 12345678
  - Buttons: Generate New PIN, Reset PIN to Default
  - Wi-Fi Protected Status: Enabled / Configured
  - Button: Reset to Unconfigured

On the right side, there are 'Helpful Hints..' sections with text explaining the settings and a 'More...' link at the bottom.



**Enable Auto**

**Channel Scan:** The Auto Channel Scan setting can be selected to allow the DAP-1522 to choose the channel with the least amount of interference.

**Wireless**

**Channel:** Indicates the channel setting for the DAP-1522. The Channel can be changed to fit the channel setting for an existing wireless network or to customize the wireless network. If you enable Auto Channel Scan, this option will be grayed out.

**Transmission**

**Rate:** Select the transmit rate. It is strongly suggested to select **Best (automatic)** for best performance.

**Channel Width:**

Select the Channel Width:

**Auto 20/40** - Select if you are using both 802.11n and non-802.11n wireless devices.

**20MHz** - Select if you are not using any 802.11n wireless clients.

**Visibility**

**Status:** Select **Invisible** if you do not want the SSID of your wireless network to be broadcasted by the DAP-1522. If Invisible is selected, the SSID of the DAP-1522 will not be seen by Site Survey utilities so your wireless clients will have to know the SSID of your DAP-1522 in order to connect to it.

**Security Mode:**

Refer to page 65 for more information regarding the wireless security.

**Enable:**

Enable the Wi-Fi Protected Setup feature.

**Lock Wireless**

**Security Settings:** Locking the wireless security settings prevents the settings from being changed by any new external user using its PIN. Devices can still be added to the wireless network using Wi-Fi Protected Setup. It is still possible to change wireless network settings with Manual Wireless Network Setup, Wireless Network Setup Wizard, or an existing external WLAN Manager user.

**Current PIN:**

Shows the current value of the access point's PIN.

**Generate New**

**PIN:** Create a random number that is a valid PIN. This becomes the access point's PIN. You can then copy this PIN to the user interface of the user.

**Reset PIN to**

**Default:** Restore the default PIN of the access point.

**Reset to**

**Unconfigured:** Resets Wi-Fi Protected Status to Not Configured. Vista WPS icon will only be displayed when the Wi-Fi Protected Status is Not Configured.

# Network Settings

## DHCP

This section will allow you to change the local network settings of the access point and to configure the DHCP settings.

**LAN Connection Type:** Use the drop-down menu to select Dynamic IP (DHCP) to automatically obtain an IP address on the LAN/private network.

**Device Name:** Enter the Device Name of the AP. It is recommended to change the Device Name if there is more than one D-Link device within the subnet.

The screenshot shows the D-Link web interface for the DAP-1522. The main navigation bar includes 'D-Link' and 'DAP-1522'. Below this is a menu with 'SETUP', 'ADVANCED', 'MAINTENANCE', 'STATUS', and 'HELP'. The 'NETWORK SETTINGS' section is highlighted in orange. It contains the following text: 'Use this section to configure the internal network settings of your access point and also to configure the built-in DHCP Server to assign IP addresses to the computers on your network. The IP Address that is configured here is the IP Address that you use to access the Web-based management interface. If you change the IP Address here, you may need to adjust your PC's network settings to access the network again.' Below this text are two buttons: 'Save Settings' and 'Don't Save Settings'. The 'LAN SETTINGS' section is also visible, with the same introductory text. Under 'LAN SETTINGS', the 'LAN Connection Type' is set to 'Dynamic IP (DHCP)' via a dropdown menu. At the bottom, the 'DEVICE NAME (NETBIOS NAME)' field is filled with 'dlinkap'. On the right side, there is a 'Helpful Hints..' section with a 'More...' link.

## Static IP

Select Static IP Address if all the Internet port's IP information is provided to you by your ISP. You will need to enter in the IP address, subnet mask, gateway address, and DNS address(es) provided to you by your ISP. Each IP address entered in the fields must be in the appropriate IP form, which are four octets separated by a dot (x.x.x.x). The Access point will not accept the IP address if it is not in this format.

**LAN Connection** Use the drop-down menu to select Static IP if your **Type:** ISP assigned you the IP address, subnet mask, gateway, and DNS server addresses. Select Dynamic IP (DHCP) to automatically assign an IP address to the computers on the LAN/private network.

**Access Point IP Address:** Enter the IP address of the access point. The default IP address is 192.168.0.50. If you change the IP address, once you click **Apply**, you will need to enter the new IP address in your browser to get back into the configuration utility.

**Subnet Mask:** Enter the Subnet Mask assigned by your ISP.

**Default Gateway:** Enter the Gateway assigned by your ISP.

**Device Name:** Enter the Device Name of the AP. It is recommended to change the Device Name if there is more than one D-Link device within the subnet.

The screenshot shows the D-Link DAP-1522 web-based configuration utility. The interface is divided into several sections:

- Header:** D-Link logo and navigation tabs: SETUP, ADVANCED, MAINTENANCE, STATUS, HELP.
- Left Sidebar:** WIRELESS SETTINGS, NETWORK SETTINGS (selected).
- Main Content Area:**
  - NETWORK SETTINGS:** Contains instructions for configuring internal network settings and a "Save Settings" / "Don't Save Settings" button.
  - ACCESS POINT SETTINGS:** Contains fields for:
    - LAN Connection Type: Static IP (selected)
    - Access Point IP Address: 192.168.0.50
    - Subnet Mask: 255.255.255.0
    - Default Gateway: (empty)
  - DEVICE NAME (NETBIOS NAME):** Contains a field for Device Name: dlinkap
- Right Sidebar:** Helpful Hints... section with text explaining LAN settings and a "More..." link.

# Advanced MAC Address Filter

The MAC address filter section can be used to filter network access by machines based on the unique MAC addresses of their network adapter(s). It is most useful to prevent unauthorized wireless devices from connecting to your network. A MAC address is a unique ID assigned by the manufacturer of the network adapter.

**Configure MAC Filtering:** When “Turn MAC Filtering OFF” is selected, MAC addresses are not used to control network access. When “Turn MAC Filtering ON and ALLOW computers listed to access the network” is selected, only computers with MAC addresses listed in the MAC Address List are granted network access. When “Turn MAC Filtering ON and DENY computers listed to access the network” is selected, any computer with a MAC address listed in the MAC Address List is refused access to the network.

**Add MAC Filtering Rule:** This parameter allows you to manually add a MAC filtering rule. Click the Add button to add the new MAC filtering rule to the MAC Filtering Rules list at the bottom of this screen.

**D-Link**

DAP-1522

SETUP ADVANCED MAINTENANCE STATUS HELP

**MAC ADDRESS FILTER**

The MAC (Media Access Controller) Address filter option is used to control network access based on the MAC Address of the network adapter. A MAC address is a unique ID assigned by the manufacturer of the network adapter. This feature can be configured to ALLOW or DENY network access.

Save Settings Don't Save Settings

**MAC FILTERING SETUP**

Configure MAC Filtering below :

Turn MAC Filtering OFF

**ADD MAC FILTERING RULE**

MAC Address : [ ] : [ ] : [ ] : [ ] : [ ] Add

**MAC FILTERING RULES**

MAC Address	Delete	MAC Address	Delete

**Helpful Hints...**

Create a list of MAC addresses that you would either like to allow or deny access to your network.

Select filter OFF, ALLOW or DENY, enter a MAC address, and then click the "Add" button to add a new MAC filtering rule.

Click the delete icon to remove the MAC address from the MAC filtering rules.

More...

# Advanced Wireless

**Transmit Power:** Sets the transmit power of the antennas.

**Beacon Period:** Beacons are packets sent by an Access Point to synchronize a wireless network. Specify a value. 100 is the default setting and is recommended.

**DTIM Interval:** (Delivery Traffic Indication Message) 1 is the default setting. A DTIM is a countdown informing clients of the next window for listening to broadcast and multicast messages.

**RTS Threshold:** This value should remain at its default setting of 2346. If inconsistent data flow is a problem, only a minor modification should be made.

**Fragmentation Threshold:** The fragmentation threshold, which is specified in bytes, determines whether packets will be fragmented. Packets exceeding the 2346 byte setting will be fragmented before transmission. 2346 is the default setting.

**WMM Enable:** WMM is QoS for your wireless network. This will improve the quality of video and voice applications for your wireless clients.

**Short GI:** Check this box to reduce the guard interval time therefore increasing the data capacity. However, it is less reliable and may create higher data loss.

**IGMP Snooping:** This enables IGMP snooping for the wireless connection. We recommend enabling this if you often use multicast services such as video conferencing and streaming audio/video.

**D-Link**

DAP-1522 // SETUP ADVANCED MAINTENANCE STATUS HELP

**ADVANCED WIRELESS**

If you are not familiar with these Advanced Wireless settings, please read the help section before attempting to modify these settings.

Save Settings Don't Save Settings

**ADVANCED WIRELESS SETTINGS**

Transmit Power : 100% ▾

Beacon Period : 100 (msec, range:25~500, default:100)

DTIM Interval : 1 (range: 1~15, default:1)

RTS Threshold : 2346 (range: 256~2346, default:2346)

Fragmentation Threshold : 2346 (range: 1500~2346, default:2346, even number only)

WMM Enable :

Short GI :

IGMP Snooping :

**Helpful Hints...**

It is recommended that you leave these parameters at their default values. Adjusting them could limit the performance of your wireless network.

Enabling WMM can help control latency and jitter when transmitting multimedia content over a wireless connection.

[More...](#)

# WLAN Partition

WLAN Partition allows you to segment your Wireless network by managing access to both the internal station and Ethernet access to your WLAN.

**Internal Station Connection:** Use the drop-down menu to either Allow or Deny internal station connection.

**Ethernet to WLAN Access:** Use the drop-down menu to either Allow or Deny Ethernet to Wireless LAN access.

The screenshot shows the D-Link DAP-1522 web interface. The top navigation bar includes tabs for SETUP, ADVANCED, MAINTENANCE, STATUS, and HELP. The left sidebar lists various configuration options: MAC ADDRESS FILTER, ADVANCED WIRELESS, WLAN PARTITION (selected), DHCP SERVER, QOS, TRAFFIC MANAGER, and SCHEDULE. The main content area is titled 'WLAN PARTITION SETTINGS' and contains two settings: 'Internal Station Connection' and 'Ethernet to WLAN Access', both set to 'Allow'. There are 'Save Settings' and 'Don't Save Settings' buttons. A 'Helpful Hints...' section on the right provides additional information about the default values for these settings.

D-Link	
DAP-1522 //	SETUP   ADVANCED   MAINTENANCE   STATUS   HELP
MAC ADDRESS FILTER	<b>WLAN PARTITION SETTINGS</b>
ADVANCED WIRELESS	Save Settings   Don't Save Settings
WLAN PARTITION	<b>WLAN PARTITION SETTINGS</b>
DHCP SERVER	Internal Station Connection : <input type="text" value="Allow"/>
QOS	Ethernet to WLAN Access : <input type="text" value="Allow"/>
TRAFFIC MANAGER	
SCHEDULE	
	<b>Helpful Hints...</b> The Internal Station Connection default value is "enable." This allows stations to inter-communicate by connecting to the target AP. Disabling this function prevents wireless stations from exchanging data through an AP. The Ethernet to WLAN Access default value is

# DHCP Server

DHCP stands for Dynamic Host Control Protocol. The DAP-1522 has a built-in DHCP server. The DHCP Server will automatically assign an IP address to the computers on the LAN/private network. Be sure to set your computers to be DHCP clients by setting their TCP/IP settings to “Obtain an IP Address Automatically.” When you turn your computers on, they will automatically load the proper TCP/IP settings provided by the DAP-1522. The DHCP Server will automatically allocate an unused IP address from the IP address pool to the requesting computer.

**Enable DHCP Server:** Check to enable the DHCP Server on the access point.

**IP Address From/To:** Enter the IP address range to assign to the clients on your network.

**Note:** If you statically (manually) assign IP addresses to your computers or devices, make sure the IP addresses are outside of this range or you may have an IP conflict.

**Default Subnet Mask:** Enter the subnet mask.

**Default Gateway:** Enter the default gateway IP address.

**Default Wins:** Enter the WINS server IP address.

**Default DNS:** Enter the DNS server IP address.

**DHCP Lease Time:** Enter the DHCP lease time (in minutes).

**DHCP Client List:** Clients on your network that are assigned IP addresses will be displayed here.

The screenshot shows the D-Link DAP-1522 web interface. The top navigation bar includes 'DAP-1522', 'SETUP', 'ADVANCED', 'MAINTENANCE', 'STATUS', and 'HELP'. The 'ADVANCED' tab is selected, and the 'NETWORK SETTING' section is highlighted. Below this, there is a 'DHCP SERVER SETTINGS' section with the following fields:

- Enable DHCP Server:
- IP Assigned From: 192.168.0.20 to 254
- Default Subnet Mask: 255.255.255.0
- Default Gateway: [ ]
- Default Wins: [ ]
- Default DNS: [ ]
- DHCP Lease Time: 10080 (minutes)

Below the settings is a 'DHCP CLIENT LIST' table with columns for Host Name, IP Address, MAC Address, and Expired Time. At the bottom, there is a '16 - DHCP RESERVATION' section with a table for reserving IP addresses:

Computer Name	IP Address	MAC Address	
<input type="checkbox"/>	[ ]	[ ]	<< Computer Name
<input type="checkbox"/>	[ ]	[ ]	<< Computer Name
<input type="checkbox"/>	[ ]	[ ]	<< Computer Name

On the right side of the interface, there is a 'Helpful Hints...' section with the text: "If you already have a DHCP server on your network or are using static IP addresses on all the devices on your network, uncheck **Enable DHCP Server** to disable this feature." and a 'More...' link.

## DHCP Reservation

If you want a computer or device to always have the same IP address assigned, you can create a DHCP reservation. The access point will assign the IP address only to that computer or device.

**Note:** This IP address must be within the DHCP IP Address Range.

**Enable:** Check this box to enable the reservation.

**Computer Name:** Enter the computer name or select from the drop-down menu.

**IP Address:** Enter the IP address you want to assign to the computer or device. This IP Address must be within the DHCP IP Address Range.

**MAC Address:** Enter the MAC address of the computer or device.



# QoS

The Quality of Service (QoS) feature regulates the flow of data through the access point by assigning a priority to each packet. It enhances your experience of wireless network usage by prioritizing the traffic of different applications. Enabling this option allows the AP to prioritize traffic. There are two options available for the special application.

**Enable QoS:** Enable this option if you want QoS to prioritize your traffic.

**QoS Type:** There are two options available for your special application: (1) Priority by LAN Port, and (2) Priority by Protocol.

**Priority by LAN Port:** There are four priority levels for all LAN ports. The priority level values assigned are 1 for Background, 3 for Best Effort, 5 for Video, and 7 for Voice (Voice is the highest level and Background is the lowest level) at a normal priority.

The screenshot shows the D-Link DAP-1522 web interface. The top navigation bar includes 'D-Link' and 'DAP-1522'. Below this is a menu with 'SETUP', 'ADVANCED', 'MAINTENANCE', 'STATUS', and 'HELP'. The 'ADVANCED' tab is selected, and the 'QoS' section is highlighted. The 'QoS' section contains the following settings:

- QoS:** QoS prioritizes the traffic of various wireless applications. There are 'Save Settings' and 'Don't Save Settings' buttons.
- QoS:** 'Enable QoS' is unchecked. 'QoS Type' is set to 'Priority by LAN Port'.
- PORT QoS:** Four dropdown menus for LAN Port 1, 2, 3, and 4, all set to 'Background'.

On the right side, there is a 'Helpful Hints...' section with the following text:

Enable this option if you want to allow QoS to prioritize wireless traffic.

There are two options for QoS Type selected, such as priority by Lan port and by protocol, which ensure the right priorities available for your special applications.

More...

**Priority by Protocol:** Users can set the priority and percentage of total bandwidth reserved for each of their four traffic categories. Please note that the combined percentage value of transmission limits does not have to be 100%. These percentages represent the maximum bandwidth designated for each traffic category.

**Wireless to Ethernet:** The value entered here indicates the wireless to Ethernet speed required before the Advanced QoS function is enabled. Advanced QoS will be enabled once the total bandwidth reaches or surpasses the set value. The suggested range is 800 ~ 96000kbits/sec.

**Ethernet to Wireless:** The value entered here indicates the Ethernet to wireless speed required before the Advanced QoS function is enabled. Advanced QoS will be enabled once the total bandwidth reaches or surpasses the set value. The suggested range is 800 ~ 96000kbits/sec.

**ACK/DHCP/ICMP/DNS Priority:** Represents the priority value and bandwidth limit applied to ACK, DHCP, ICMP, and DNS for packet delivering.

**Web Traffic Priority:** Traffic generated by typical Web services (packets sent through ports 80,443, 3128 and 8080).

**Mail Traffic Priority:** Traffic generated by e-mail sending and receiving (ports 25, 110, 465 and 995).

**Ftp Traffic Priority:** Traffic generated by FTP Uploading and Downloading (ports 20, 21).

**Other Traffic Priority:** Other traffic generated that does not regard the aforementioned packet delivery.

**Note:** Normally the wireless connection transmits application data packets based on the wireless to Ethernet speed and Ethernet to wireless speed. Users can treat the two speeds as system transmission bandwidth, where all applications will share the whole system bandwidth based on assigned priorities. Note that the maximum amount of bandwidth that can be used is the same as the set value of both speeds.

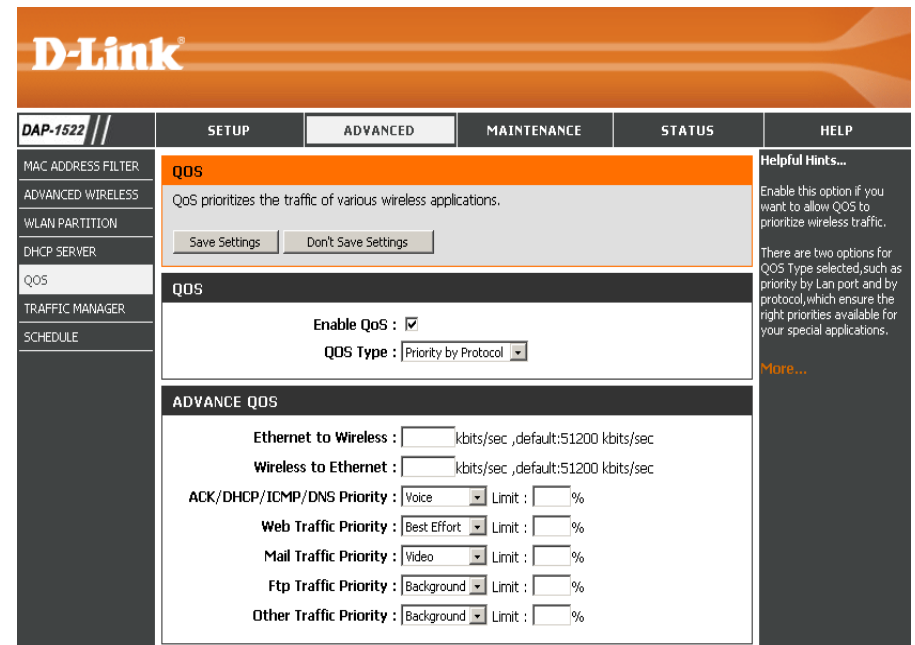

# Traffic Manager

Traffic Manager assigns the device's entire bandwidth, which includes both the wireless to Ethernet speed and Ethernet to wireless speed. The user may add rules for data transmission performance between the access point device and the individual client. For unlisted client traffic, users can either choose to deny or forward packet transferred for such clients.

**Enable Traffic Manager:** Traffic Manager enables traffic control of the delivering and receiving of data packets.

**Unlisted Clients Traffic:** There are two options available for Unlisted Clients Traffic: (1) deny, and (2) forward.

**Ethernet to Wireless:** This section allows the user to indicate the device's maximum bandwidth from Ethernet to wireless.

**Wireless to Ethernet:** This section allows the user to indicate the device's maximum bandwidth from wireless to Ethernet.

The screenshot shows the D-Link DAP-1522 web interface. The top navigation bar includes 'D-Link', 'DAP-1522', and tabs for 'SETUP', 'ADVANCED', 'MAINTENANCE', 'STATUS', and 'HELP'. The 'ADVANCED' tab is selected, and the 'TRAFFIC MANAGER' section is active.

**TRAFFIC MANAGER**  
 Traffic Manager gives you control of your network traffic, increasing the efficiency of your network and reducing your overall bandwidth requirements.

Save Settings    Don't Save Settings

**TRAFFIC MANAGER**

Traffic Manager :  Enable  Disable

Unlisted Clients Traffic :  Deny  Forward

Ethernet to Wireless :  kbits/sec ,default:51200 kbits/sec

Wireless to Ethernet :  kbits/sec ,default:51200 kbits/sec

**ADD TRAFFIC MANAGER RULE**

Name :

Client IP(optional):

Client MAC(optional):

Ethernet to Wireless :  kbits/sec

Wireless to Ethernet :  kbits/sec

Add    Clear

**TRAFFIC MANAGER RULES**

Name	Client Ip	Client Mac	Ethernet to Wireless Speed	Wireless to Ethernet Speed	Edit Del

**WIRELESS**

**Helpful Hints...**  
 Enable this option if you want to allow TRAFFIC MANAGER to control wireless traffic speed.  
 For most applications, the traffic manager ensure the right traffic speed and specific traffic manager rules are not required.  
 More...

## Add Traffic Manager Rule

In Traffic Manager Rule enter settings for each user of your network, using adequate IP (Client IP) or MAC address (Client MAC). Set appropriate Ethernet to Wireless and Wireless to Ethernet speeds for the traffic you want to regulate.

**Name:** Enter a name for your new rule.

**Client IP (optional):** The IP address assigned to the client.

**Client MAC (optional) :** By assigning MAC addresses to the set of traffic manager rules, specific rules can be defined for individual devices.

**Ethernet to Wireless:** Represents the available bandwidth for client data to be forwarded from Ethernet to wireless, the suggested range is 800 ~ 96000kbits/sec.

**Wireless to Ethernet:** Represents the available bandwidth for client data to be forwarded from wireless to Ethernet, the suggested range is 800 ~ 96000kbits/sec.

**Note:** Normally the wireless connection transmits application data packets based on the wireless to Ethernet speed and Ethernet to wireless speed. Users can treat the two speeds as system transmission bandwidth, where all applications will share the whole system bandwidth based on assigned priorities. Note that the maximum amount of bandwidth that can be used is the same as the set value of both speeds.

# Schedule

**Name:** Enter a name for your new schedule.

**Days:** Select a day, a range of days, or All Week to include every day.

**Time:** Check **All Days** or enter a start and end time for your schedule.

**Wireless:** Select **On** or **Off** from the drop-down menu.

**Add:** Click **Add** to save your schedule. You must click **Save Settings** at the top for your schedules to go into effect.

**Schedule Rules List:** The list of schedules will be listed here. Click the **Edit** icon to make changes or click the **Delete** icon to remove the schedule.

**D-Link**

DAP-1522 //

SETUP | **ADVANCED** | MAINTENANCE | STATUS | HELP

MAC ADDRESS FILTER  
ADVANCED WIRELESS  
WLAN PARTITION  
DHCP SERVER  
QOS  
TRAFFIC MANAGER  
SCHEDULE

**WIRELESS SCHEDULE SETTINGS**

Save Settings | Don't Save Settings

**WIRELESS SCHEDULE SETTINGS**

Wireless Schedule :

**ADD SCHEDULE RULE**

Name :

Day(s) :  All Week  Select Day(s)  
 Sun  Mon  Tue  Wed  Thu  Fri  Sat

All Day(s)

Start Time :  :  (hour:minute, 24 hour time)

End Time :  :  (hour:minute, 24 hour time)

Wireless :

Add Clear

**SCHEDULE RULE LIST**

Name	Day(s)	Time Frame	Wireless	Edit Delete

**WIRELESS**

**Helpful Hints...**  
DAP-1522's radio can be scheduled by week or by individual days.  
[More...](#)

# Tools Admin

This page will allow you to change the Administrator password. The administrator password has read/write access.

**Password:** Enter a new password for the Administrator Login Name. The administrator can make changes to the settings.

**Verify Password:** Enter the same password that you entered in the previous textbox in order to confirm its accuracy.

The screenshot shows the D-Link DAP-1522 web interface. At the top is the D-Link logo. Below it is a navigation menu with tabs for SETUP, ADVANCED, MAINTENANCE, STATUS, and HELP. On the left is a sidebar with menu items: ADMIN, TIME, SYSTEM, and FIRMWARE. The main content area is titled 'ADMINISTRATOR SETTINGS' and contains the following text: 'The 'admin' accounts can access the management interface. The admin has read/write access and can change passwords.' and 'By default there is no password configured. It is highly recommended that you create a password to keep your access point secure.' Below this text are two buttons: 'Save Settings' and 'Don't Save Settings'. Below the buttons is a section titled 'ADMIN PASSWORD' with the instruction 'Please enter the same password into both boxes, for confirmation.' and two password input fields labeled 'Password' and 'Verify Password'. On the right side of the main content area is a 'Helpful Hints..' sidebar with the text: 'For security reasons, it is recommended that you change the password for the Admin and User accounts. Be sure to write down the new and passwords to avoid having to reset the access point in case they are forgotten.' and a 'More...' link.

# Time

The Time Configuration option allows you to configure, update, and maintain the correct time on the internal system clock. From this section you can set the time zone that you are in. Daylight Saving can also be configured to automatically adjust the time when needed.

**Time Zone:** Select the Time Zone from the drop-down menu.

**Daylight Saving:** To select Daylight Saving time manually, tick the **Enable Daylight Saving** check box. Next use the drop-down menu to select a Daylight Saving Offset and then enter a start date and an end date for daylight saving time.

**Date and Time:** To manually input the time, enter the values in these fields for the Year, Month, Day, Hour, Minute, and Second and then click Save Settings. You can also click the **Copy Your Computer's Time Settings** button at the bottom of the screen.

The screenshot shows the D-Link DAP-1522 web interface. The top navigation bar includes 'DAP-1522 //', 'SETUP', 'ADVANCED', 'MAINTENANCE', 'STATUS', and 'HELP'. The left sidebar lists 'ADMIN', 'TIME', 'SYSTEM', and 'FIRMWARE'. The main content area is titled 'TIME' and contains the following sections:

- TIME:** A descriptive paragraph about the Time Configuration option and two buttons: 'Save Settings' and 'Don't Save Settings'.
- TIME CONFIGURATION:**
  - Time: 01/01/2000 00:36:54
  - Time Zone: [(GMT-08:00) Pacific Time (US & Canada); Tijuana]
  - Enable Daylight Saving:
  - Daylight Saving Offset: [+1:00]
  - Daylight Saving Dates:
 

	Month	Week	Day of Week	Time
DST Start	Jan	1st	Sun	12 am
DST End	Jan	1st	Sun	12 am
- SET THE DATE AND TIME MANUALLY:**
  - Date And Time: Year [2009], Month [Jan], Day [5], Hour [3], Minute [53], Second [50], [PM]
  - Copy Your Computer's Time Settings button

The bottom of the page features a 'WIRELESS' logo.

# System

**Save to Local Hard Drive:** Use this option to save the current access point configuration settings to a file on the hard disk of the computer you are using. First, click the **Save** button. You will then see a file dialog, where you can select a location and file name for the settings.

**Load from Local Hard Drive:** Use this option to load previously saved access point configuration settings. First, use the Browse control to find a previously save file of configuration settings. Then, click the **Load** button to transfer those settings to the access point.

**Restore to Factory Default:** This option will restore all configuration settings back to the settings that were in effect at the time the access point was shipped from the factory. Any settings that have not been saved will be lost, including any rules that you have created. If you want to save the current access point configuration settings, use the **Save** button above.

**Note:** Restoring the factory default settings will not reset the Wi-Fi Protected Status to Not Configured.

**Reboot the Device:** Click to reboot the access point.

**Clear Language Pack:** Click to clear the language pack. This will put the web UI back to English.

The screenshot shows the D-Link web interface for the DAP-1522. The top navigation bar includes tabs for SETUP, ADVANCED, MAINTENANCE, STATUS, and HELP. The left sidebar contains links for ADMIN, TIME, SYSTEM, and FIRMWARE. The main content area is titled 'SYSTEM SETTINGS' and contains the following options:

- Save To Local Hard Drive :** Save Configuration
- Load From Local Hard Drive :** Includes a text input field, a 'Browse...' button, and a 'Restore Configuration from File' button.
- Restore To Factory Default :** Restore Factory Defaults. Below this is the text: 'Restore all settings to the factory defaults.'
- Reboot The Device :** Reboot the Device
- Clear Language Pack :** Clear

On the right side, there is a 'Helpful Hints...' section with the following text:

Once your access point is configured the way you want it, you can save the configuration settings to a configuration file.

You might need this file so that you can load your configuration later in the event that the access point's default settings are restored.

To save the configuration, click the "Save Configuration" button.

[More...](#)



# Firmware

You can upgrade the firmware of the access point here. Make sure the firmware you want to use is on the local hard drive of the computer. Click on Browse to locate the firmware file to be used for the update. Please check the D-Link support website for firmware updates at <http://support.dlink.com>. You can download firmware upgrades to your hard drive from this site.

**Browse:** After you have downloaded the new firmware, click Browse to locate the firmware update on your hard drive. Click Upload to complete the firmware upgrade.

**Upload:** Once you have a firmware update on your computer, use this option to browse for the file and then upload the information into the access point.

## Language Pack

You can change the language of the web UI by uploading available language packs.

**Browse:** After you have downloaded the new language pack, click **Browse** to locate the language pack file on your hard drive. Click **Upload** to complete the language pack upgrade.

The screenshot displays the D-Link web interface for a DAP-1522 access point. The top navigation bar includes tabs for SETUP, ADVANCED, MAINTENANCE, STATUS, and HELP. The left sidebar lists menu items: ADMIN, TIME, SYSTEM, and FIRMWARE. The main content area is divided into several sections:

- FIRMWARE:** Contains instructions to use the Firmware section to install the latest firmware code to improve functionality and performance. It includes buttons for "Save Settings" and "Don't Save Settings".
- FIRMWARE INFORMATION:** Displays the current firmware version as 1.20 and the current firmware date as 15:25:36 11/21/2008.
- FIRMWARE UPGRADE:** Includes a note that some firmware upgrades reset configuration options to factory defaults. It instructs users to save current configuration from the Maintenance -> Admin screen. Below the note, it states that a wired connection is required and provides an "Upload" field with a "Browse..." button and an "Upload" button.
- LANGUAGE PACKAGE INFORMATION:** Includes a note that updating the language package will change the language display on the web page. It also instructs users to have a wired connection and provides another "Upload" field with a "Browse..." button and an "Upload" button.

On the right side of the interface, there is a "Helpful Hints..." section with text about firmware updates and a "More..." link.

If you load a language pack and would like to go back to English, click **Maintenance > System** and click on **Clear** next to **Clear Language Pack**.

DAP-1522	SETUP	ERWEITERT	WARTUNG	STATUS	HILFE
ADMIN	<b>SYSTEMEINSTELLUNGEN</b>				<p><b>Nützliche Hinweise...</b></p> <p>Sobald Ihr Access Point wie gewünscht konfiguriert ist, können Sie die Konfigurationseinstellungen in einer Konfigurationsdatei speichern.</p> <p>Sie benötigen diese Datei möglicherweise, damit Sie Ihre Konfiguration später laden können, falls die Standardeinstellungen des Access Point wiederhergestellt wurden.</p> <p>Klicken Sie auf die Schaltfläche "Konfiguration speichern", um die Konfiguration zu speichern.</p> <p>Mehr...</p>
ZEIT	<p>Im Abschnitt "Systemeinstellungen" können Sie das Gerät neu starten oder den Access Point auf die Werkseinstellungen zurücksetzen. Wenn das Gerät auf die Werkseinstellungen zurückgesetzt wird, werden alle Einstellungen, einschließlich aller von Ihnen erstellten Regeln, gelöscht.</p> <p>Die aktuellen Systemeinstellungen können als Datei auf der lokalen Festplatte gespeichert werden. Die gespeicherte Datei oder eine andere vom Gerät erstellte, gespeicherte Einstellungsdatei kann in das Gerät geladen werden.</p>				
SYSTEM	<p><b>SYSTEMEINSTELLUNGEN</b></p> <p><b>Auf der lokalen Festplatte speichern:</b> <input type="button" value="Konfiguration speichern"/></p> <p><b>Von der lokalen Festplatte laden:</b> <input type="text"/> <input type="button" value="Browse..."/> <input type="button" value="Konfiguration von Datei wiederherstellen"/></p> <p><b>Auf Werkseinstellungen zurücksetzen:</b> <input type="button" value="Werkseinstellungen wiederherstellen"/> Alle Einstellungen auf die Werkseinstellungen zurücksetzen.</p> <p><b>Starten Sie das Gerät neu:</b> <input type="button" value="Starten Sie das Gerät neu"/></p>				
FIRMWARE	<p><b>Sprachpaket löschen:</b> <input type="button" value="Entfernen"/></p>				

DAP-1522	CONFIGURACIÓN	AVANZADO	MANTENIMIENTO	ESTADO	AYUDA
ADMINISTRADOR	<b>PARÁMETROS DEL SISTEMA</b>				<p><b>Sugerencias útiles...</b></p> <p>Una vez que el punto de acceso está configurado como lo desea, puede guardar los parámetros de configuración en un archivo de configuración.</p> <p>Puede que necesite este archivo para poder cargar la configuración más adelante en el caso de que se restablezcan los parámetros predeterminados del punto de acceso.</p> <p>Para guardar la configuración, haga clic en el botón "Guardar configuración".</p> <p>Más información...</p>
HORA	<p>La sección Parámetros del sistema le permite reiniciar el dispositivo o restaurar el punto de acceso a los parámetros predeterminados de fábrica. Al restaurar en la unidad los parámetros predeterminados de fábrica se borrarán todos los parámetros, incluidas las reglas que haya creado.</p> <p>Se pueden guardar los parámetros del sistema actual como un archivo en la unidad de disco duro local. Puede cargarse en la unidad el archivo guardado o cualquier otro archivo de parámetros guardado creado por el dispositivo.</p>				
SISTEMA	<p><b>PARÁMETROS DEL SISTEMA</b></p> <p><b>Guardar en la unidad de disco duro local:</b> <input type="button" value="Guardar configuración"/></p> <p><b>Cargar desde la unidad de disco duro local:</b> <input type="text"/> <input type="button" value="Browse..."/> <input type="button" value="Restablecer la configuración del archivo"/></p> <p><b>Restablecer en los valores predeterminados de fábrica:</b> <input type="button" value="Restablecer valores predeterminados de fábrica"/> Restablecer todos los parámetros en los valores predeterminados de fábrica.</p> <p><b>Reinicie el dispositivo:</b> <input type="button" value="Reiniciar el dispositivo"/></p>				
FIRMWARE	<p><b>Borrar paquete de idioma:</b> <input type="button" value="Borrar"/></p>				

DAP-1522	CONFIGURATION	AVANÇÉ	MAINTENANCE	ÉTAT	AIDE
ADMIN	<b>PARAMÈTRES SYSTÈME</b>				<p><b>Conseils utiles...</b></p> <p>Une fois le point d'accès configuré comme vous le souhaitez, vous pouvez enregistrer les paramètres de configuration dans un fichier de configuration.</p> <p>Vous aurez peut-être besoin de ce fichier pour charger votre configuration ultérieurement, en cas de restauration des paramètres par défaut de votre point d'accès.</p> <p>Pour enregistrer la configuration, cliquez sur le bouton Enregistrer la configuration.</p> <p>Plus...</p>
HEURE	<p>La section Configuration du système vous permet de réinitialiser le périphérique ou de restaurer les paramètres d'usine point d'accès. Restaurer les valeurs d'usine de tous les paramètres efface tous vos paramètres, y compris toutes les règles que vous avez créées.</p> <p>La configuration actuelle du système peut être enregistrée sous forme de fichier sur le disque dur local. Le fichier enregistré ou tout autre fichier de configuration enregistré et créé par le périphérique peut être chargé sur la machine.</p>				
SYSTÈME	<p><b>PARAMÈTRES SYSTÈME</b></p> <p><b>Enregistrer sur le disque dur local:</b> <input type="button" value="Enregistrer la configuration"/></p> <p><b>Charger depuis le disque dur local:</b> <input type="text"/> <input type="button" value="Browse..."/> <input type="button" value="Restaurer la configuration à partir d'un fichier"/></p> <p><b>Restaurer les paramètres par défaut:</b> <input type="button" value="Restaurer les valeurs d'usine"/> Restaurer tous les paramètres sur les valeurs définies à l'usine.</p> <p><b>Réinitialiser le périphérique:</b> <input type="button" value="Réinitialiser le périphérique"/></p>				
MICROPROGRAMME	<p><b>Effacer le pack linguistique:</b> <input type="button" value="Effacer"/></p>				

DAP-1522	CONFIGURAZIONE	AVANZATE	MANUTENZIONE	STATO	GUIDA
ADMIN	<b>IMPOSTAZIONI SISTEMA</b>				<p><b>Suggerimenti utili...</b></p> <p>Dopo aver configurato il punto di accesso nel modo desiderato, è possibile salvare le impostazioni in un apposito file di configurazione.</p> <p>Tale file potrebbe essere necessario per caricare la configurazione in un secondo momento qualora venissero ripristinate le impostazioni predefinite del punto di accesso.</p> <p>Per salvare la configurazione, fare clic sul pulsante "Salva configurazione".</p> <p>Altro...</p>
ORA	<p>La sezione Impostazioni sistema consente di riavviare il dispositivo o di ripristinare le impostazioni predefinite del punto di accesso. Il ripristino delle impostazioni predefinite comporta la cancellazione di tutte le impostazioni precedenti, incluse eventuali regole create dall'utente.</p> <p>È possibile salvare le impostazioni di sistema correnti in un file del disco fisso locale. Il file salvato o qualsiasi altro file di impostazioni salvato creato dal dispositivo può quindi essere caricato nell'unità.</p>				
SISTEMA	<p><b>IMPOSTAZIONI SISTEMA</b></p> <p><b>Salva su Disco fisso locale:</b> <input type="button" value="Salva configurazione"/></p> <p><b>Carica da disco fisso locale:</b> <input type="text"/> <input type="button" value="Browse..."/> <input type="button" value="Ripristina configurazione da file"/></p> <p><b>Ripristina impostazioni predefinite:</b> <input type="button" value="Ripristina impostazioni predefinite"/> Ripristina tutte le impostazioni predefinite.</p> <p><b>Riavvio del dispositivo:</b> <input type="button" value="Riavvio del dispositivo"/></p>				
FIRMWARE	<p><b>Cancela Language Pack:</b> <input type="button" value="Cancella"/></p>				

# Status

## Device Info

This page displays the current information for the DAP-1522. It will display the LAN and wireless LAN information.

**General:** Displays the access point's time and firmware version.

**LAN:** Displays the MAC address and the private (local) IP settings for the access point.

**Wireless LAN:** Displays the wireless MAC address and your wireless settings such as SSID and Channel.

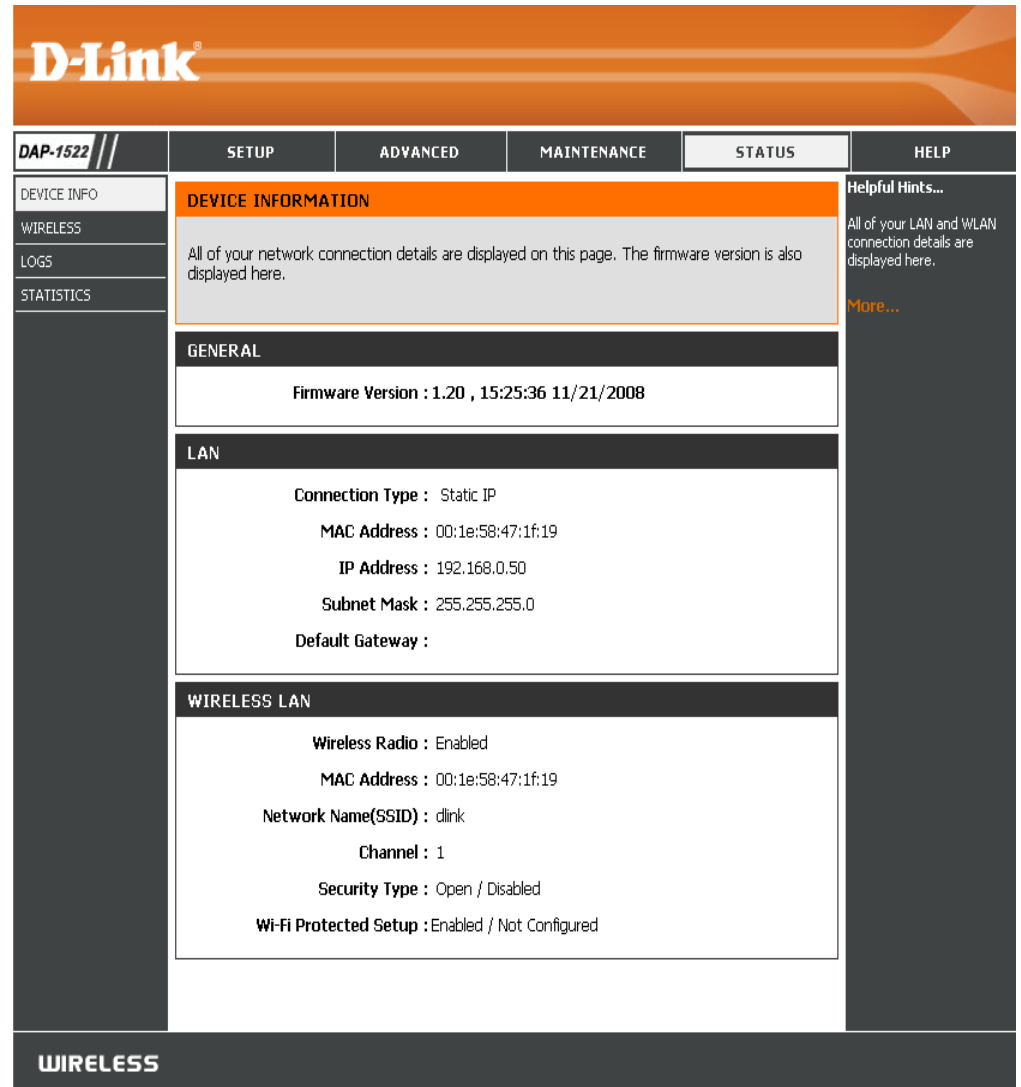

The screenshot shows the D-Link web interface for the DAP-1522. The top navigation bar includes tabs for SETUP, ADVANCED, MAINTENANCE, STATUS (selected), and HELP. The left sidebar contains a menu with options: DAP-1522, DEVICE INFO (selected), WIRELESS, LOGS, and STATISTICS. The main content area is titled 'DEVICE INFORMATION' and contains a summary of network connection details. Below this, there are three sections: GENERAL, LAN, and WIRELESS LAN, each displaying specific configuration parameters.

GENERAL
Firmware Version : 1.20 , 15:25:36 11/21/2008

LAN
Connection Type : Static IP
MAC Address : 00:1e:58:47:1f:19
IP Address : 192.168.0.50
Subnet Mask : 255.255.255.0
Default Gateway :

WIRELESS LAN
Wireless Radio : Enabled
MAC Address : 00:1e:58:47:1f:19
Network Name(SSID) : dlink
Channel : 1
Security Type : Open / Disabled
Wi-Fi Protected Setup : Enabled / Not Configured

Helpful Hints...  
All of your LAN and WLAN connection details are displayed here.  
[More...](#)

WIRELESS

# Wireless

The wireless section allows you to view the wireless clients that are connected to your wireless access point.

**MAC Address:** The Ethernet ID (MAC address) of the wireless client.

**UpTime:** Displays the amount of time the wireless client has been connected to the access point.

**Mode:** The transmission standard being used by the client. Values are 11a, 11b, 11g, 11ng or 11na for 802.11a, 802.11b, 802.11g or 802.11n respectively.

**Signal:** This is a relative measure of signal quality. The value is expressed as a percentage of theoretical best quality. Signal quality can be reduced by distance, by interference from other radio-frequency sources (such as cordless telephones or neighboring wireless networks), and by obstacles between the access point and the wireless device.

The screenshot shows the D-Link web interface for the DAP-1522. The top navigation bar includes the D-Link logo and tabs for SETUP, ADVANCED, MAINTENANCE, STATUS, and HELP. The left sidebar contains links for DEVICE INFO, WIRELESS, LOGS, and STATISTICS. The main content area is titled 'WIRELESS' and contains the following text:

View the wireless clients that are connected to your access point.

NUMBER OF WIRELESS CLIENTS : 0

MAC Address	UpTime	Mode	Signal (%)
(No clients listed)			

On the right side, there is a 'Helpful Hints..' section with the text: 'This is a list of all wireless clients that are currently connected to your access point.' and a 'More...' link.

# Logs

The access point automatically logs (records) events of possible interest in its internal memory. If there isn't enough internal memory for all events, logs of older events are deleted, but logs of the latest events are retained. The Logs option allows you to view the access point logs. You can define what types of events you want to view and the level of the events to view. This access point also has external Syslog Server support so you can send the log files to a computer on your network that is running a Syslog utility

**What to View:** There are three types of logs that can be viewed: System Activity, Wireless Activity, and Notice. Tick the corresponding check box for the type(s) that you want displayed in the log.

**Enable Remote Log:** Select the check box and enter a Log Server name or IP address to enable the remote log feature.

**Apply Log Settings Now:** Click this button to immediately filter the log results so that only the selected options appear in the Log Details section of this screen.

**Refresh:** Updates the log details on the screen so it displays any recent activity.

**Clear:** Clear all of the log contents.

**Save Log:** This option will save the access point to a log file on your computer.

The screenshot shows the D-Link web interface for a DAP-1522 access point. The main content area is titled 'LOGS' and contains the following sections:

- LOGS:** View the logs. You can define the event levels to view.
- LOG OPTIONS:**
  - What to View:** Three checkboxes are checked: System Activity, Wireless Activity, and Notice.
  - Enable Remote Log:** An unchecked checkbox.
  - Log Server / IP Address:** An empty text input field.
  - Apply Log Settings Now:** A button.
- LOG DETAILS:**
  - Navigation buttons: First Page, Last Page, Previous, Next, Clear, Refresh, Save Log.
  - Page 1 of 3
  - Table of log entries:

Time	Priority	Message
Uptime 0 day 10:09:00	[SYSACT]	Web login success from 192.168.0.5
Uptime 0 day 10:08:52	[SYSACT]	Device is operating in AP mode!
Uptime 0 day 10:08:48	[Wireless]	Stop Wireless success
Uptime 0 day 10:08:48	[Wireless]	Initiate Wireless success
Uptime 0 day 10:08:48	[Wireless]	Auto channel:Best channel is 48
Uptime 0 day 10:08:48	[Wireless]	Stop Wireless success
Uptime 0 day 09:55:44	[Wireless]	Initiate Wireless success
Uptime 0 day 09:55:39	[Wireless]	Stop Wireless success
Uptime 0 day 09:55:39	[Wireless]	Initiate Wireless success
Uptime 0 day 09:55:38	[Wireless]	Stop Wireless success

**Helpful Hints..** Check the log frequently to detect unauthorized network usage. [More...](#)

# Statistics

The Statistics page displays all of the LAN and Wireless packets transmit and receive statistics.

**TX Packets:** The total number of packets sent from the access point.

**RX Packets:** The total number of packets received by the access point.

**TX Packets Dropped:** Displays the number of packets that were dropped while sending, due to errors, collisions, or access point resource limitations.

**RX Packets Dropped:** Displays the number of packets that were dropped while receiving, due to errors, collisions, or access point resource limitations.

**TX Bytes:** Displays the number of bytes that were sent from the access point.

**RX Bytes:** Displays the number of bytes that were received by the access point.

The screenshot shows the D-Link web interface for the DAP-1522 device. The main navigation bar includes tabs for SETUP, ADVANCED, MAINTENANCE, STATUS, and HELP. The left sidebar contains links for DEVICE INFO, WIRELESS, LOGS, and STATISTICS. The main content area is titled 'TRAFFIC STATISTICS' and includes a description: 'Traffic Statistics display receive and transmit packets passing through your access point.' Below this are two buttons: 'Refresh Statistics' and 'Clear Statistics'. The statistics are divided into two sections: LAN STATISTICS and WIRELESS STATISTICS.

LAN STATISTICS	
TX Packets Packets : 2798	RX Packets Packets : 5235
TX Packets Dropped : 0	RX Packets Dropped : 0
TX Packets Bytes : 3145352	RX Packets Bytes : 362978

WIRELESS STATISTICS	
TX Packets Packets : 0	RX Packets Packets : 0
TX Packets Dropped : 0	RX Packets Dropped : 0
TX Packets Bytes : 0	RX Packets Bytes : 0

On the right side of the interface, there is a 'Helpful Hints..' section with a 'More...' link. The hint text reads: 'This is a summary of the number of packets that have passed between the WAN and the LAN since the access point was last initialized.'

# Help

**D-Link**

**DAP-1522** //

SETUP    ADVANCED    MAINTENANCE    STATUS    **HELP**

**MENU**

- SETUP
- ADVANCED
- MAINTENANCE
- STATUS

**SUPPORT MENU**

**Setup Help**

- [Wireless Settings](#)
- [Network Settings](#)

**Advanced Help**

- [MAC Address Filter](#)
- [Advanced Wireless](#)
- [WLAN Partition](#)
- [DHCP Server](#)
- [QoS](#)
- [Traffic Manager](#)
- [Schedule](#)

**Maintenance Help**

- [Admin](#)
- [Time](#)
- [System](#)
- [Firmware](#)

**Status Help**

- [Device Info](#)
- [Wireless](#)
- [Logs](#)
- [Statistics](#)

Helpful Hints...

# Configuration for Bridge Mode

This section will show you how to configure your new D-Link wireless MediaBridge using the web-based configuration utility.

## Web-based Configuration Utility

To access the configuration utility, open a web-browser such as Internet Explorer and enter dlinkap or enter 192.168.0.50 in the address field.

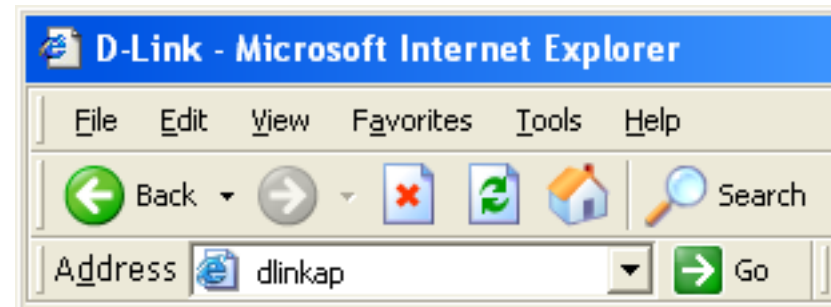

Select **Admin** from the drop-down menu and then enter your password. Leave the password blank by default.

If you get a Page Cannot be Displayed error, please refer to the Troubleshooting section for assistance.

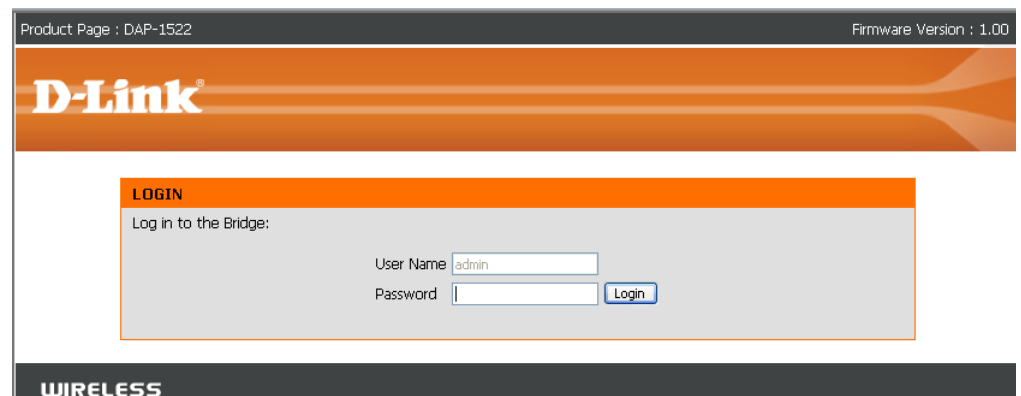



# Setup Wizard

This wizard is designed to assist you in configuring the wireless settings for your bridge. It will guide you through step-by-step instructions on how to setup your wireless network.

Click Launch Wireless Setup Wizard to begin.

Click Launch Wireless Setup Wizard

The screenshot shows the D-Link web interface for the DAP-1522. The top navigation bar includes 'D-Link', 'DAP-1522', and tabs for 'SETUP', 'ADVANCED', 'MAINTENANCE', 'STATUS', and 'HELP'. The left sidebar has a tree view with 'WIZARD', 'WIRELESS', and 'NETWORK SETTINGS'. The main content area displays the 'MICROSOFT WINDOWS CONNECT NOW WIZARD' with instructions and a 'Launch Wireless Setup Wizard' button. A red note below the button states: 'Note: Some changes made using this Setup Wizard may require you to change some settings on your wireless client adapters so they can still connect to the D-Link Access Point.' A 'Helpful Hints..' section on the right provides additional guidance for new users.

Enter the Device Name of the AP and click **Next** to continue. It is recommended to change the Device Name if there is more than one D-Link device within the subnet.

The screenshot shows the 'SET YOUR DEVICE NAME' step of the Setup Wizard. The page header includes 'Product Page : DAP-1522' and 'Firmware Version : 1.00'. The main content area has an orange header 'SET YOUR DEVICE NAME' and instructions: 'Enter the Device Name of the AP. Recommend to change the Device Name if there're more than one D-Link devices within the subnet. Click **Next** to continue.' Below the instructions is a text input field labeled 'Device Name (NetBIOS Name)' with the value 'dlinkap' entered. At the bottom of the form are 'Next' and 'Exit' buttons. The left sidebar shows 'WIRELESS' selected.

If you want to change the admin account password, enter a new password and click **Next**.



**SET YOUR NEW PASSWORD**

You may change the **admin** account password by entering in a new password. Click **Next** to continue.

Password :

Verify Password :



Select **Auto** configuration if you want to use Wi-Fi Protected Setup.

If you want to set up your network manually, skip to page 53.

Click **Next** to continue.

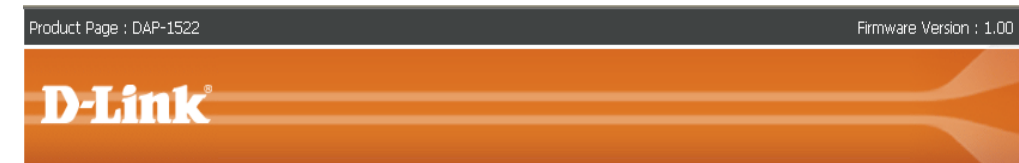

**SELECT CONFIGURATION METHOD**

Please select one of the following configuration methods and click next to continue.

**Auto** (Select this option if you want to use Wi-Fi Protected Setup)

**Manual** (Select this option if you want to setup your network manually)



Select **PIN** to connect your wireless device with WPS.

For **PBC** configuration, skip to page 52.

Enter the **PIN** number used into you access point and click Connect.

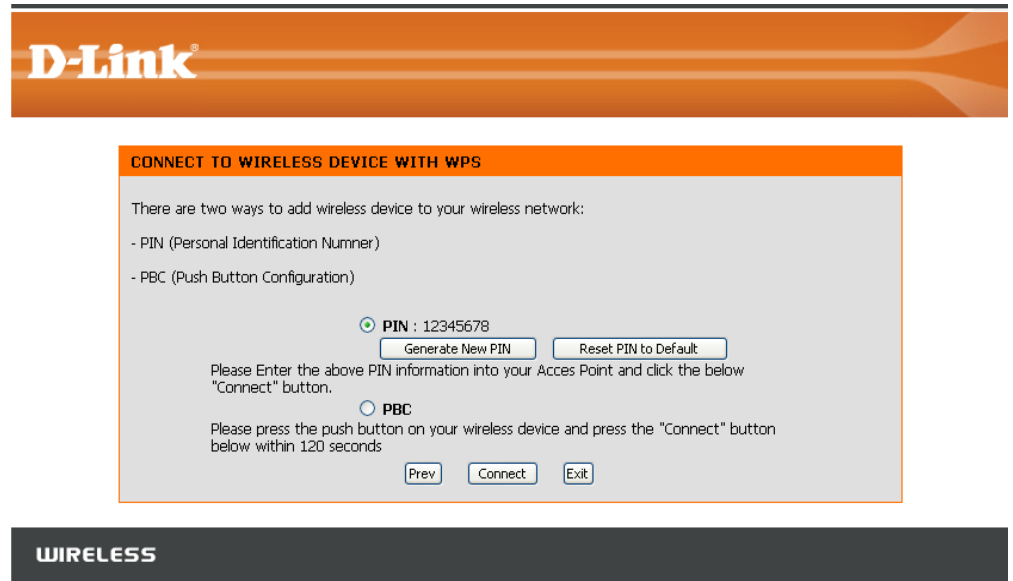

Start WPS on the wireless device you are adding to you wireless network to complete the setup.

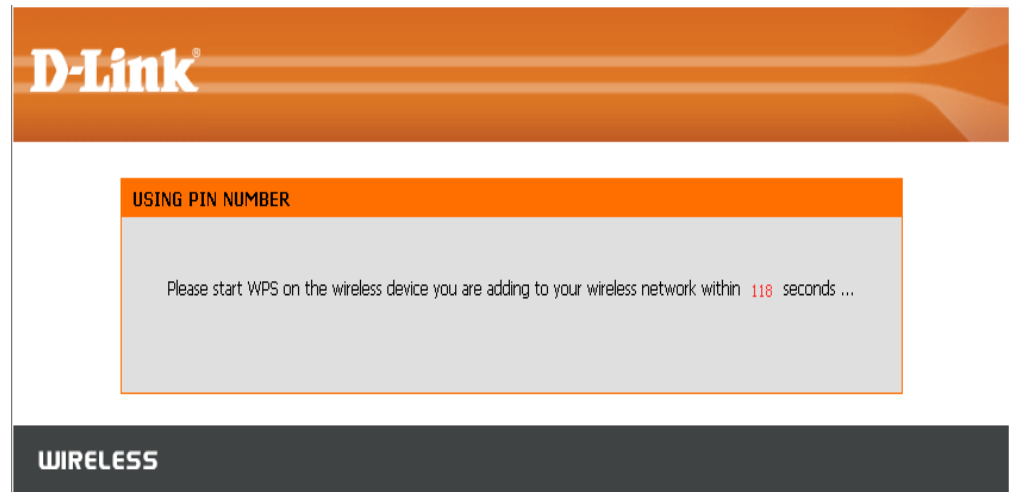

Select **PBC** to use the Push Button Configuration to connect to your network.

Click **Connect** to continue.

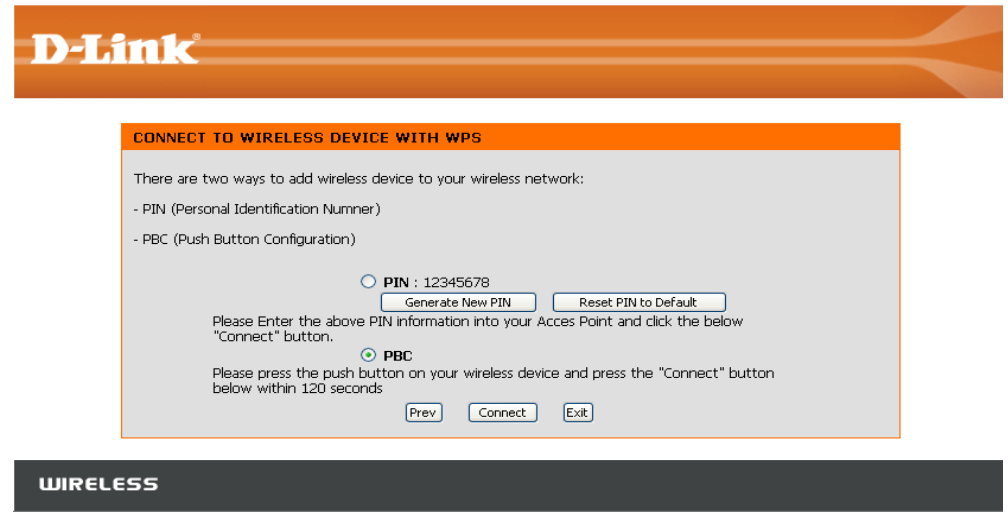

Press down the Push Button on the wireless device you are adding to your network to complete the setup.

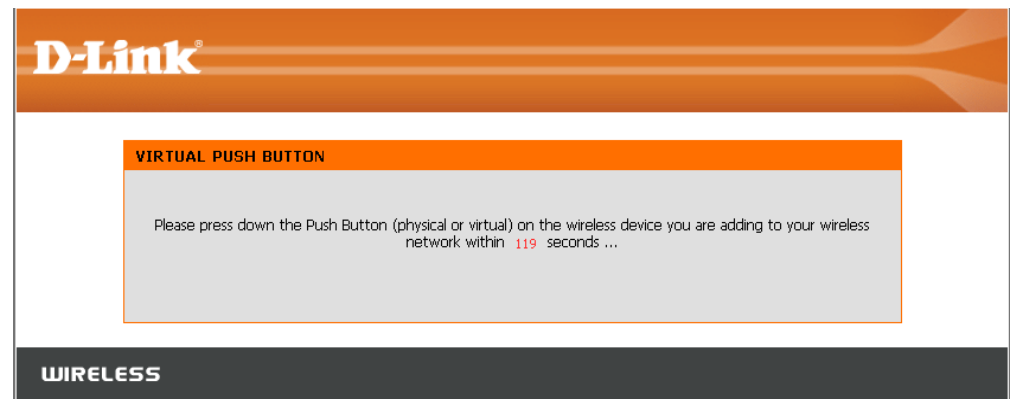

Select **Manual** configuration to set up your network manually.

Click **Next** to continue.

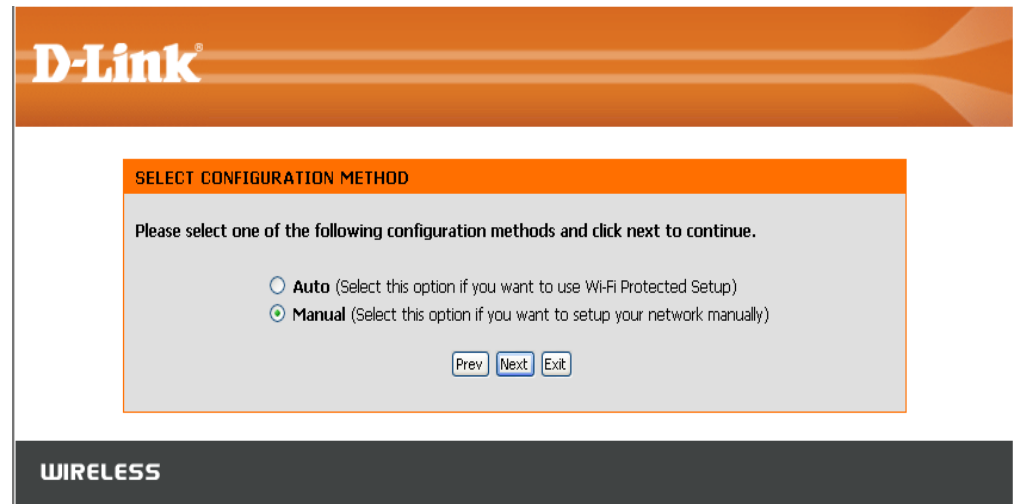

Enter the **Wireless Network Name** of the AP or click the Site Survey button to find the AP.

Click **Next** to continue on to page 54.

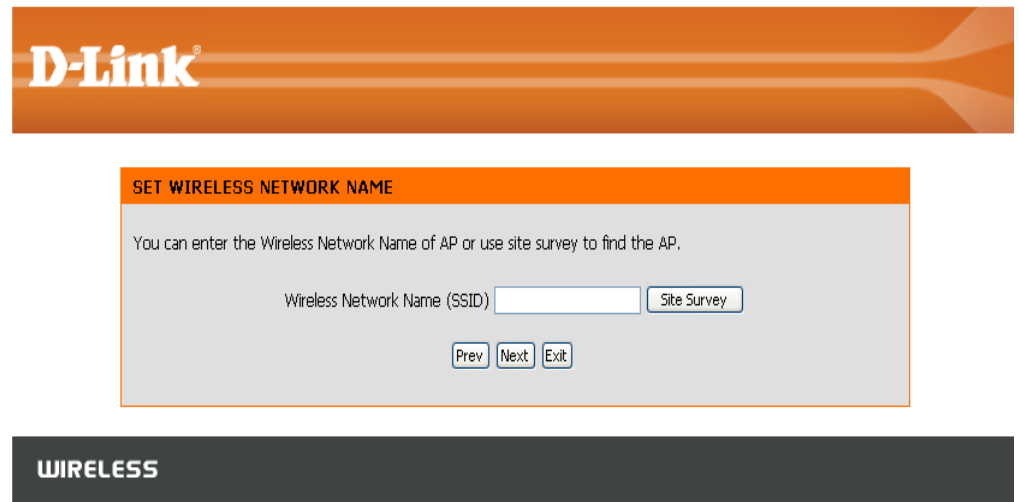

If you clicked on **Site Survey**, the following screen will be displayed.

Find your access point from the list and click **Connect** to complete the Setup Wizard.

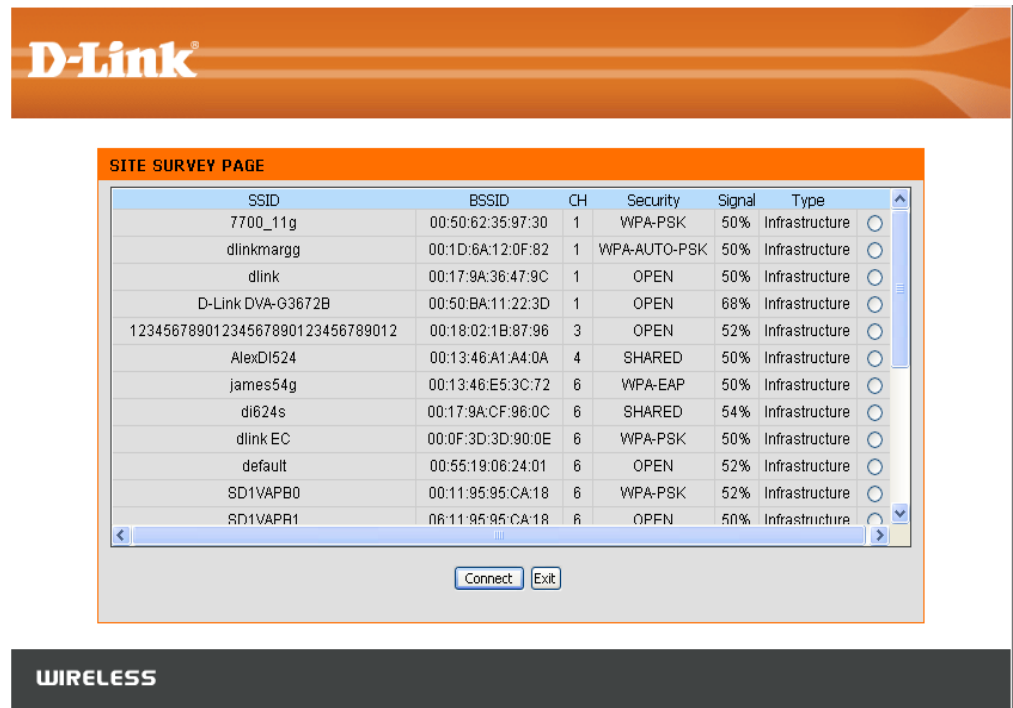

**D-Link**

**SITE SURVEY PAGE**

SSID	BSSID	CH	Security	Signal	Type
7700_11g	00:50:62:35:97:30	1	WPA-PSK	50%	Infrastructure
dlinkmargg	00:1D:6A:12:0F:82	1	WPA-AUTO-PSK	50%	Infrastructure
dlink	00:17:9A:36:47:9C	1	OPEN	50%	Infrastructure
D-Link DVA-G3672B	00:50:BA:11:22:3D	1	OPEN	68%	Infrastructure
12345678901234567890123456789012	00:18:02:1B:87:96	3	OPEN	52%	Infrastructure
AlexD1524	00:13:46:A1:A4:0A	4	SHARED	50%	Infrastructure
james54g	00:13:46:E5:3C:72	6	WPA-EAP	50%	Infrastructure
dj624s	00:17:9A:CF:96:0C	6	SHARED	54%	Infrastructure
dlink EC	00:0F:3D:3D:90:0E	6	WPA-PSK	50%	Infrastructure
default	00:55:19:06:24:01	6	OPEN	52%	Infrastructure
SD1VAPB0	00:11:95:95:CA:18	6	WPA-PSK	52%	Infrastructure
SD1VAPB1	00:11:95:95:CA:18	6	OPEN	50%	Infrastructure

**Connect** **Exit**

**WIRELESS**

Choose which Security Mode you want to use and click **Next** to continue.

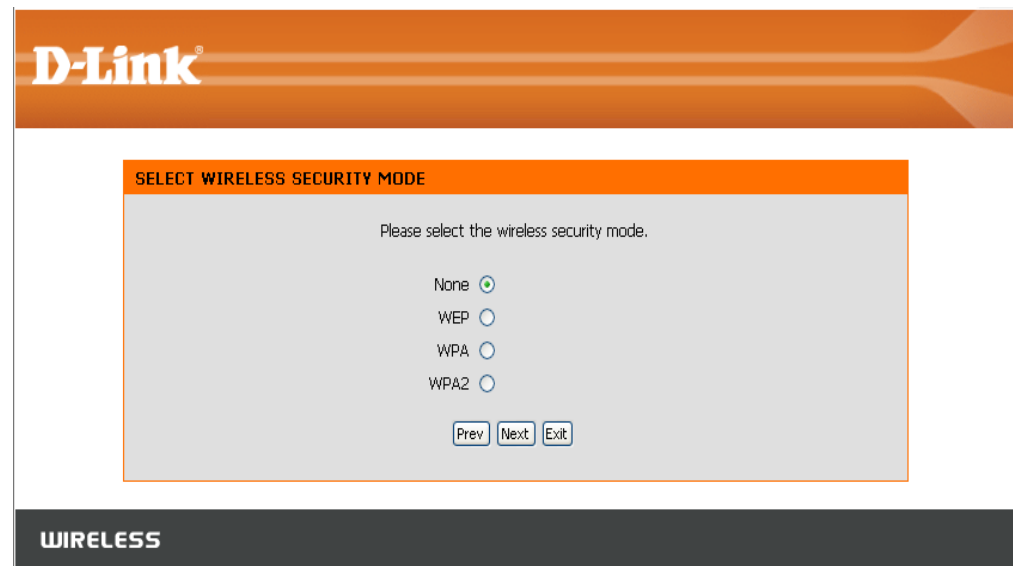

**D-Link**

**SELECT WIRELESS SECURITY MODE**

Please select the wireless security mode.

None

WEP

WPA

WPA2

**Prev** **Next** **Exit**

**WIRELESS**

If you choose **WEP**, enter the wireless security password and click **Next** to complete the Setup Wizard.

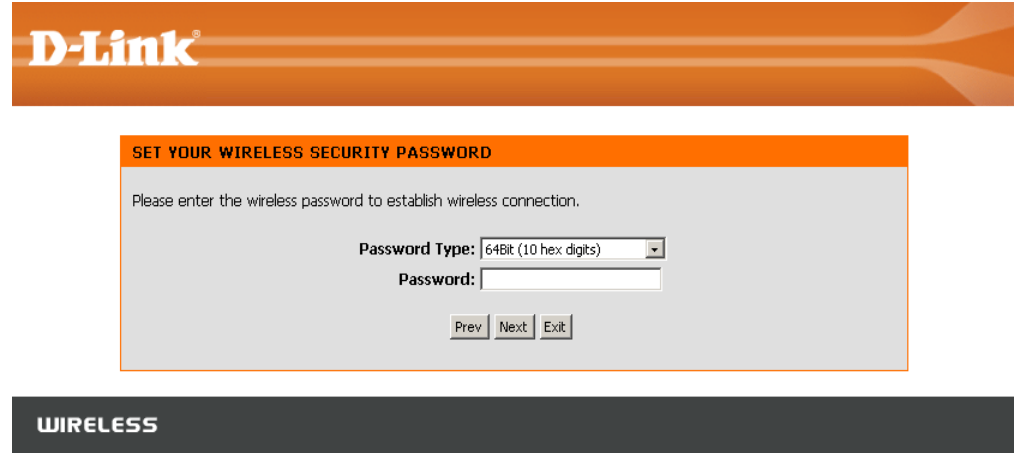

If you choose **WPA**, enter the **WPA** Personal Passphrase and click Next to complete the Setup Wizard.

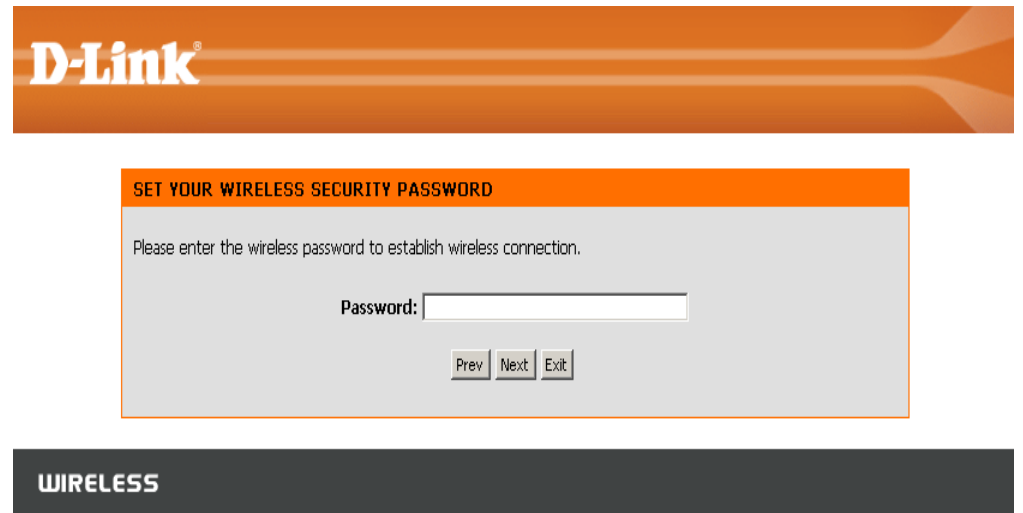

If you choose WPA2, enter the WPA2 Personal Passphrase and click Next to complete the Setup Wizard.

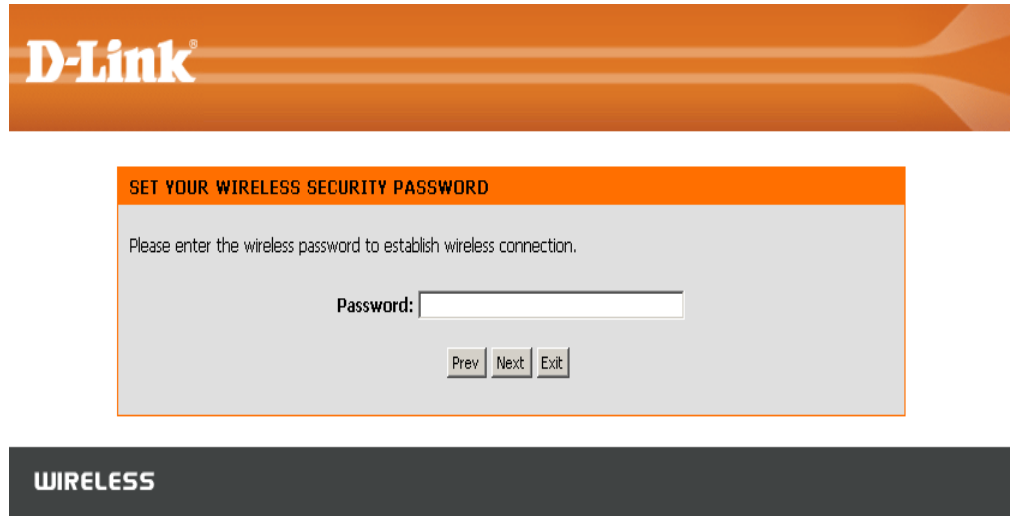

The following screen opens to indicate that you have successfully saved your new settings.

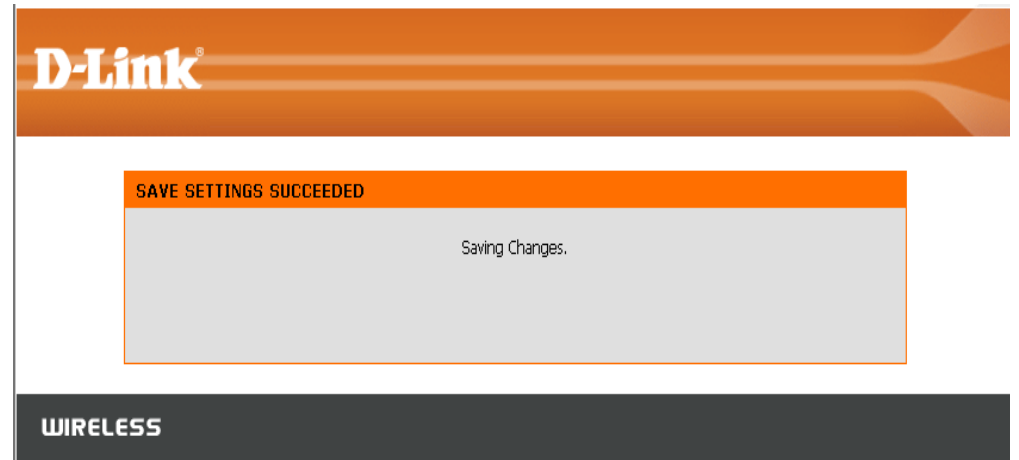



# Wireless

**Wireless Mode:** Select Infrastructure to connect to a wireless (AP) Access Point, select Ad-hoc to connect to another bridge or wireless station.

**Site Survey:** A function that looks for available wireless networks.

**Enable Wireless:** Click the check box to enable the wireless function. If you do not want to use wireless, uncheck the box to disable all the wireless functions.

**Wireless Network Name:** Service Set Identifier (SSID) is the name of your wireless network. Create a name using up to 32 characters. The SSID is case-sensitive.

**802.11 Band:** The options include 2.4GHz, 5GHz, and 2.4GHz/5GHz. This option is unavailable in Bridge Mode.

**802.11 Mode:** If all of the wireless devices in your wireless network can connect in the same transmission mode, you can improve performance slightly by choosing the appropriate “Only” mode. If you have some devices that use a different transmission mode, choose the appropriate “Mixed” mode. This option is unavailable in Bridge Mode.

**Enable Auto Channel Scan:** The Auto Channel Scan setting is used to allow the DAP-1522 to choose the channel with the least amount of interference. This option is unavailable in Bridge Mode.

**Wireless Channel:** Indicates the channel setting for the DAP-1522. The Channel can be changed to fit the channel setting for an existing wireless network or to customize the wireless network. This option is unavailable in Bridge Mode.

Product Page : DAP-1522 Firmware Version : 1.10

**D-Link**

DAP-1522 // SETUP ADVANCED MAINTENANCE STATUS HELP

WIZARD WIRELESS NETWORK SETTINGS

**WIRELESS NETWORK**

Use this section to configure the wireless settings for your access point. Please note that changes made on this section may also need to be duplicated on your Wireless Client.

Save Settings Don't Save Settings

**WIRELESS NETWORK SETTINGS**

Wireless Mode: Bridge Mode

Enable Wireless:

Wireless Network Name:  (Also called the SSID)

802.11 Band:  2.4GHz  5GHz  2.4GHz/5GHz

802.11 Mode:

Enable Auto Channel Scan:

Wireless Channel:

Transmission Rate:  (Mbit/s)

Channel Width:

Visibility Status:  Visible  Invisible

**WIRELESS SECURITY MODE**

Security Mode:

**WI-FI PROTECTED SETUP (ALSO CALLED WCN 2.0 IN WINDOWS VISTA)**

Enable:

**WIRELESS MAC CLONING**

Enable:

MAC Source:

MAC Address:

Port: MAC Address

WIRELESS

**Helpful Hints...**

Select the SSID which you want your bridge to connect to.

If you have enabled Wireless Security, make sure you write down the WEP Key or Passphrase that you have configured. You will need to enter this information on every wireless device that you connect to your wireless network.

[More...](#)

**Transmission Rate:** Select the transmit rate. It is strongly suggested to select Best (automatic) for best performance. This option is unavailable in Bridge Mode.

**Channel Width:** Select the Channel Width:  
Auto 20/40 - Select if you are using both 802.11n and non-802.11n wireless devices.  
20MHz - Select if you are not using any 802.11n wireless clients.

**Visibility Status:** This setting determines whether the DAP-1522 will continue to periodically broadcast its presence on the network. This option is unavailable in Bridge Mode.

**Security Mode:** Refer to page 65 for more information regarding wireless security.

**Enable:** Enable the Wi-Fi Protected Setup feature.

## Wireless MAC Cloning

Enabling this option allows the user to manually assign the source MAC address to packets forwarded by the DAP-1522. If not manually assigned, the packet's source MAC address field will be automatically selected as the DAP-1522's MAC address.

**MAC Address:** Enter the desired MAC address connected to your DAP-1522 to enable the clone function.

**Scan:** Click the **Scan** button to search for all available devices connected to your DAP-1522's Ethernet ports

# Network Settings

## Static

This section will allow you to change the local network settings of the bridge and to configure the Static settings.

**LAN Connection Type:** Use the drop-down menu to select **Static IP** if your ISP assigned you the IP address, subnet mask, gateway, and DNS server addresses. Select **Dynamic IP (DHCP)** to automatically assign an IP address to the computers on the LAN/private network.

**Access Point IP Address:** Enter the IP address assigned by your ISP.

**Subnet Mask:** Enter the Subnet Mask assigned by your ISP.

**Default Gateway:** Enter the Gateway assigned by your ISP.

**Device Name:** Enter the Device Name of the AP and click **Next** to continue. It is recommended to change the Device Name if there is more than one D-Link device within the subnet.

**D-Link**

**DAP-1522** // SETUP ADVANCED MAINTENANCE STATUS HELP

WIZARD  
WIRELESS  
NETWORK SETTINGS

**NETWORK SETTINGS**

Use this section to configure the internal network settings of your access point and also to configure the built-in DHCP Server to assign IP addresses to the computers on your network. The IP Address that is configured here is the IP Address that you use to access the Web-based management interface. If you change the IP Address here, you may need to adjust your PC's network settings to access the network again.

Save Settings Don't Save Settings

**LAN SETTINGS**

Use this section to configure the internal network settings of your access point. The IP Address that is configured here is the IP Address that you use to access the Web-based management interface. If you change the IP Address here, you may need to adjust your PC's network settings to access the network again.

LAN Connection Type : Static IP

Access Point IP Address : 192.168.0.50

Subnet Mask : 255.255.255.0

Default Gateway :

**DEVICE NAME (NETBIOS NAME)**

Device Name : dlinkap

Helpful Hints..  
If you have a DHCP server on your network, you can select DHCP to get the IP address from a DHCP server.  
More...

## DHCP

**LAN Connection Type:** Select DHCP to automatically obtain an IP address on the LAN/private network.

**Device Name:** Enter the Device Name of the AP and click **Next** to continue. It is recommended to change the Device Name if there is more than one D-Link device within the subnet.

**D-Link**

**DAP-1555** // SETUP ADVANCED MAINTENANCE STATUS HELP

**WIZARD**

**WIRELESS**

**NETWORK SETTINGS**

**NETWORK SETTINGS**

Use this section to configure the internal network settings of your bridge and also to configure the built-in DHCP Server to assign IP addresses to the computers on your network. The IP Address that is configured here is the IP Address that you use to access the Web-based management interface. If you change the IP Address here, you may need to adjust your PC's network settings to access the network again.

Save Settings Don't Save Settings

**LAN SETTINGS**

Use this section to configure the internal network settings of your bridge. The IP Address that is configured here is the IP Address that you use to access the Web-based management interface. If you change the IP Address here, you may need to adjust your PC's network settings to access the network again.

LAN Connection Type : Dynamic IP (DHCP)

**DEVICE NAME (NETBIOS NAME)**

Device Name: dlinkap

**WIRELESS**

**Helpful Hints...**

If you have a DHCP server on your network, you can select DHCP to get the IP address from a DHCP server.

More...

# Advanced Advanced Wireless

**Transmit Power:** Set the transmit power of the antennas.

**RTS Threshold:** This value should remain at its default setting of 2436. If inconsistent data flow is a problem, only a minor modification should be made.

**Fragmentation Threshold:** The fragmentation threshold, which is specified in bytes, determines whether packets will be fragmented. Packets exceeding the 2346 byte setting will be fragmented before transmission. 2346 is the default setting.

**Short GI:** Check this box to reduce the guard interval time therefore increasing the data capacity. However, it is less reliable and may create higher data loss.

The screenshot displays the D-Link DAP-1522 configuration interface. The 'ADVANCED WIRELESS' tab is active, showing the following settings:

- Transmit Power:** 100% (dropdown menu)
- RTS Threshold:** 2346 (range: 256~2346, default:2346)
- Fragmentation Threshold:** 2346 (range: 1500~2346, default:2346, even number only)
- Short GI:**

Additional elements visible in the screenshot include the D-Link logo, navigation tabs (DAP-1522, SETUP, ADVANCED, MAINTENANCE, STATUS, HELP), a sidebar menu (ADVANCED WIRELESS, QOS, SCHEDULE), and a 'Helpful Hints...' section on the right.

# QoS

The Quality of Service (QoS) feature regulates the flow of data through the access point by assigning a priority to each packet. It enhances your experience of wireless network usage by prioritizing the traffic of different applications. Enabling this option allows the AP to prioritize traffic. There are two options available for the special application.

**Enable QoS:** Enable this option if you want QoS to prioritize your traffic.

**QoS Type:** There are two options available for your special application: (1) Priority by LAN Port, and (2) Priority by Protocol.

**Priority by LAN Port:** There are four priority levels for all LAN ports. The priority level values assigned are 1 for Background, 3 for Best Effort, 5 for Video, and 7 for Voice (Voice is the highest level and Background is the lowest level) at a normal priority.

**D-Link**

DAP-1522 // SETUP ADVANCED MAINTENANCE STATUS HELP

ADVANCED WIRELESS

QoS

SCHEDULE

**QoS**

QoS prioritizes the traffic of various wireless applications.

Save Settings Don't Save Settings

**QoS**

Enable QoS :

QoS Type : Priority by LAN Port

**PORT QoS**

LAN Port 1 Priority : Background

LAN Port 2 Priority : Best Effort

LAN Port 3 Priority : Video

LAN Port 4 Priority : Voice

**Helpful Hints...**

Enable this option if you want to allow QoS to prioritize wireless traffic.

There are two options for QoS Type selected, such as priority by Lan port and by protocol, which ensure the right priorities available for your special applications.

More...

**Priority by Protocol:** Users can set the priority and percentage of total bandwidth reserved for each of their four traffic categories. Please note that the combined percentage value of transmission limits does not have to be 100%. These percentages represent the maximum bandwidth designated for each traffic category.

**Wireless to Ethernet:** The value entered here indicates the wireless to Ethernet speed required before the Advanced QoS function is enabled. Advanced QoS will be enabled once the total bandwidth reaches or surpasses the set value. The suggested range is 800 ~ 96000kbits/sec.

**Ethernet to Wireless:** The value entered here indicates the Ethernet to wireless speed required before the Advanced QoS function is enabled. Advanced QoS will be enabled once the total bandwidth reaches or surpasses the set value. The suggested range is 800 ~ 96000kbits/sec.

**ACK/DHCP/ICMP/DNS Priority:** Represents the priority value and bandwidth limit applied to ACK, DHCP, ICMP, and DNS for packet delivering.

**Web Traffic Priority:** Traffic generated by typical Web services (packets sent through ports 80,443, 3128 and 8080).

**Mail Traffic Priority:** Traffic generated by e-mail sending and receiving (ports 25, 110, 465 and 995).

**Ftp Traffic Priority:** Traffic generated by FTP Uploading and Downloading (ports 20, 21).

**Other Traffic Priority:** Other traffic generated that does not regard the aforementioned packet delivery.

**Note:** Normally the wireless connection transmits application data packets based on the wireless to Ethernet speed and Ethernet to wireless speed. Users can treat the two speeds as system transmission bandwidth, where all applications will share the whole system bandwidth based on assigned priorities. Note that the maximum amount of bandwidth that can be used is the same as the set value of both speeds.

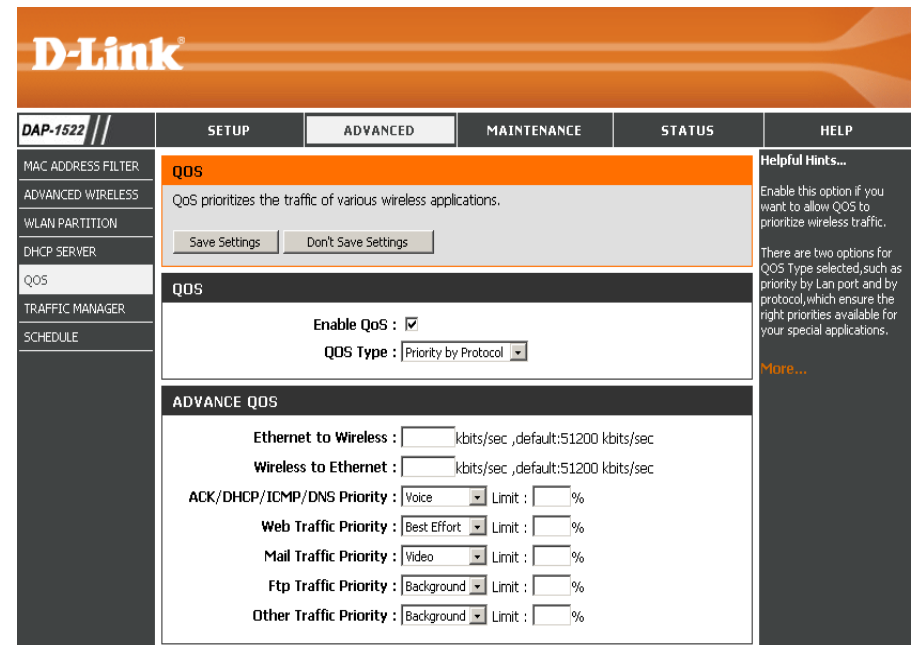

# Schedule

**Name:** Enter a name for your new schedule.

**Days:** Select a day, a range of days, or All Week to include every day.

**Time:** Check **All Days** or enter a start and end time for your schedule.

**Wireless:** Select **On** or **Off** from the drop-down menu.

**Add:** Click **Add** to save your schedule. You must click **Save Settings** at the top for your schedules to go into effect.

**Schedule Rules List:** The list of schedules will be listed here. Click the **Edit** icon to make changes or click the **Delete** icon to remove the schedule.

**D-Link**

DAP-1522 // SETUP ADVANCED MAINTENANCE STATUS HELP

ADVANCED WIRELESS WIRELESS SCHEDULE SETTINGS

Save Settings Don't Save Settings

WIRELESS SCHEDULE SETTINGS

Wireless Schedule : Disable

ADD SCHEDULE RULE

Name :

Day(s) :  All Week  Select Day(s)

Sun  Mon  Tue  Wed  Thu  Fri  Sat

All Day(s)

Start Time :  :  (hour:minute, 24 hour time)

End Time :  :  (hour:minute, 24 hour time)

Wireless : Off

Add Clear

SCHEDULE RULE LIST

Name	Day(s)	Time Frame	Wireless	Edit Delete

WIRELESS

Helpful Hints...  
DAP-1522's radio can be scheduled by week or by individual days.  
More...



# Tools Admin

This page will allow you to change the Administrator password. Admin has read/write access.

**Password:** Enter a new password for the Administrator Login Name. The administrator can make changes to the settings.

**Verify Password:** Enter the same password that you entered in the previous textbox in order to confirm its accuracy.

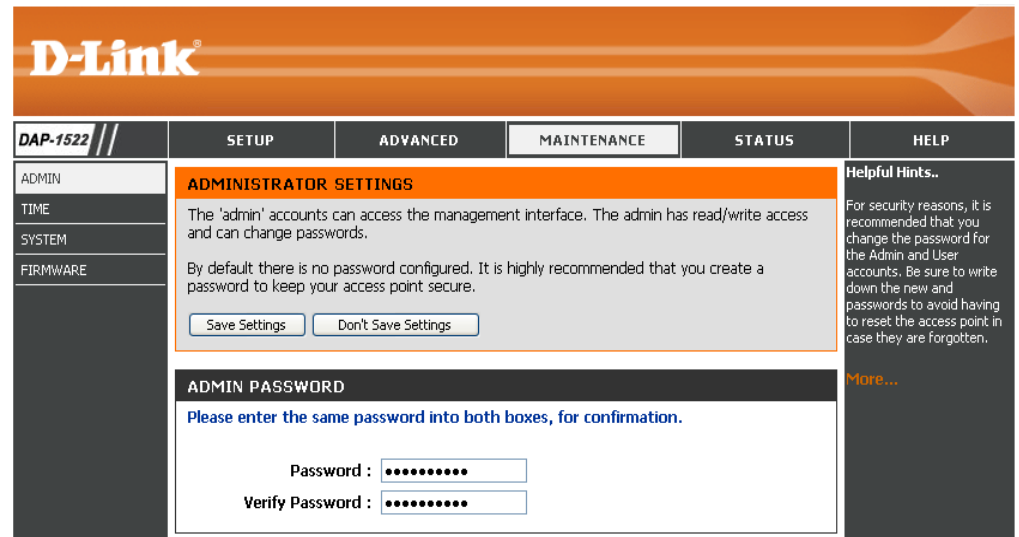

The screenshot shows the D-Link web interface for the DAP-1522 device. The top navigation bar includes the D-Link logo and tabs for SETUP, ADVANCED, MAINTENANCE, STATUS, and HELP. The left sidebar lists menu items: ADMIN, TIME, SYSTEM, and FIRMWARE. The main content area is titled 'ADMINISTRATOR SETTINGS' and contains the following text: 'The 'admin' accounts can access the management interface. The admin has read/write access and can change passwords. By default there is no password configured. It is highly recommended that you create a password to keep your access point secure.' Below this text are two buttons: 'Save Settings' and 'Don't Save Settings'. The 'ADMIN PASSWORD' section is highlighted and contains the instruction: 'Please enter the same password into both boxes, for confirmation.' Below this instruction are two password input fields: 'Password : [mask]' and 'Verify Password : [mask]'. The right sidebar, titled 'Helpful Hints..', contains a security warning: 'For security reasons, it is recommended that you change the password for the Admin and User accounts. Be sure to write down the new and passwords to avoid having to reset the access point in case they are forgotten.' and a 'More...' link.

# Time

The Time Configuration option allows you to configure, update, and maintain the correct time on the internal system clock. From this section you can set the time zone that you are in. Daylight Saving can also be configured to automatically adjust the time when needed.

**Time Zone:** Select the Time Zone from the drop-down menu.

**Daylight Saving:** To select Daylight Saving time manually, click the **Enable Daylight Saving** check box. Next, use the drop-down menu to select a Daylight Saving Offset and then enter a start date and an end date for daylight saving time.

**Date and Time:** To manually input the time, enter the values in these fields for the Year, Month, Day, Hour, Minute, and Second and then click Save Settings. You can also click the **Copy Your Computer's Time Settings** button at the bottom of the screen.

**D-Link**

DAP-1522 // SETUP ADVANCED MAINTENANCE STATUS HELP

**TIME**

The Time Configuration option allows you to configure, update, and maintain the correct time on the internal system clock. From this section you can set the time zone that you are in and set the NTP (Network Time Protocol) Server. Daylight Saving can also be configured to automatically adjust the time when needed.

Save Settings Don't Save Settings

**TIME CONFIGURATION**

Time : 01/01/2000 01:39:19  
 Time Zone : [(GMT-08:00) Pacific Time (US & Canada); Tijuana]

Enable Daylight Saving :   
 Daylight Saving Offset : [+1:00]

Daylight Saving Dates :  
 DST Start : Month [Jan] Week [1st] Day of Week [Sun] Time [12 am]  
 DST End : Month [Jan] Week [1st] Day of Week [Sun] Time [12 am]

**SET THE DATE AND TIME MANUALLY**

Date And Time : Year [2009] Month [Jan] Day [5]  
 Hour [5] Minute [39] Second [1] PM [PM]

Copy Your Computer's Time Settings

WIRELESS

Helpful Hints...  
 Good timekeeping is important for accurate logs.  
 More...

# System

**Save To Local Hard Drive:** Use this option to save the current access point configuration settings to a file on the hard disk of the computer you are using. First, click the **Save** button. You will then see a file dialog, where you can select a location and file name for the settings.

**Load From Local Hard Drive:** Use this option to load previously saved access point configuration settings. First, use the Browse control to find a previously save file of configuration settings. Then, click the **Load** button to transfer those settings to the access point.

**Restore To Factory Default:** This option will restore all configuration settings back to the settings that were in effect at the time the access point was shipped from the factory. Any settings that have not been saved will be lost, including any rules that you have created. If you want to save the current access point configuration settings, use the **Save** button above.

**Reboot The Device:** Click to reboot the bridge.

**Clear Language Pack:** Click to clear the language pack. This will put the web UI back to English.

The screenshot shows the D-Link DAP-1522 web interface. The top navigation bar includes the D-Link logo and tabs for SETUP, ADVANCED, MAINTENANCE, STATUS, and HELP. The left sidebar contains a menu with options: ADMIN, TIME, SYSTEM (selected), and FIRMWARE. The main content area is titled "SYSTEM SETTINGS" and contains the following options:

- Save To Local Hard Drive :** Save Configuration
- Load From Local Hard Drive :** [Browse...] Restore Configuration from File
- Restore To Factory Default :** Restore Factory Defaults  
Restore all settings to the factory defaults.
- Reboot The Device :** Reboot the Device
- Clear Language Pack :** Clear

On the right side, there is a "Helpful Hints..." section with the following text:

Once your access point is configured the way you want it, you can save the configuration settings to a configuration file.

You might need this file so that you can load your configuration later in the event that the access point's default settings are restored.

To save the configuration, click the "Save Configuration" button.

[More...](#)

# Firmware

You can upgrade the firmware of the access point here. Make sure the firmware you want to use is on the local hard drive of the computer. Click on **Browse** to locate the firmware file to be used for the update. Please check the D-Link support site for firmware updates at <http://support.dlink.com>. You can download firmware upgrades to your hard drive from the D-Link support site.

**Browse:** After you have downloaded the new firmware, click **Browse** to locate the firmware update on your hard drive. Click **Upload** to complete the firmware upgrade.

**Upload:** Once you have a firmware update on your computer, use this option to browse for the file and then upload the information into the bridge.

## Language Pack

You can change the language of the web UI by uploading available language packs.

**Browse:** After you have downloaded the new language pack, click **Browse** to locate the language pack file on your hard drive. Click **Upload** to complete the language pack upgrade.

The screenshot displays the D-Link web interface for a DAP-1522 access point. The top navigation bar includes 'DAP-1522', 'SETUP', 'ADVANCED', 'MAINTENANCE', 'STATUS', and 'HELP'. The left sidebar lists 'ADMIN', 'TIME', 'SYSTEM', and 'FIRMWARE'. The main content area is divided into three sections:

- FIRMWARE:** Contains instructions to use the section for installing the latest firmware code. It includes 'Save Settings' and 'Don't Save Settings' buttons.
- FIRMWARE INFORMATION:** Shows 'Current Firmware Version : 1.20' and 'Current Firmware Date : 15:25:36 11/21/2008'.
- FIRMWARE UPGRADE:** Includes a red note: 'Note: Some firmware upgrades reset the configuration options to the factory defaults. Before performing an upgrade, be sure to save the current configuration from the Maintenance -> Admin screen.' Below this, instructions state: 'To upgrade the firmware, your PC must have a wired connection to the access point. Enter the name of the firmware upgrade file, and click on the Upload button.' There is an 'Upload' field with a 'Browse...' button and an 'Upload' button.

The bottom section is **LANGUAGE PACKAGE INFORMATION**, which includes a red note: 'Note: Update language package will make changes language display on web page. Before performing an upgrade, be sure to do it!' and instructions: 'To upgrade the language package, your PC must have a wired connection to the access point. Enter the name of the language package upgrade file, and click on the Upload button.' It also features an 'Upload' field with a 'Browse...' button and an 'Upload' button.

On the right side, there is a 'Helpful Hints...' section with text about firmware updates and a 'More...' link.

If you load a language pack and would like to go back to English, click **Maintenance > System** and click on **Clear** next to **Clear Language Pack**.

DAP-1522	SETUP	ERWEITERT	WARTUNG	STATUS	HILFE
ADMIN	<b>SYSTEMEINSTELLUNGEN</b>				<p><b>Nützliche Hinweise...</b></p> <p>Sobald Ihr Access Point wie gewünscht konfiguriert ist, können Sie die Konfigurationseinstellungen in einer Konfigurationsdatei speichern.</p> <p>Sie benötigen diese Datei möglicherweise, damit Sie Ihre Konfiguration später laden können, falls die Standardeinstellungen des Access Point wiederhergestellt wurden.</p> <p>Klicken Sie auf die Schaltfläche "Konfiguration speichern", um die Konfiguration zu speichern.</p> <p>Mehr...</p>
ZEIT	<p>Im Abschnitt "Systemeinstellungen" können Sie das Gerät neu starten oder den Access Point auf die Werkseinstellungen zurücksetzen. Wenn das Gerät auf die Werkseinstellungen zurückgesetzt wird, werden alle Einstellungen, einschließlich aller von Ihnen erstellten Regeln, gelöscht.</p> <p>Die aktuellen Systemeinstellungen können als Datei auf der lokalen Festplatte gespeichert werden. Die gespeicherte Datei oder eine andere vom Gerät erstellte, gespeicherte Einstellungsdatei kann in das Gerät geladen werden.</p>				
SYSTEM	<p><b>SYSTEMEINSTELLUNGEN</b></p> <p><b>Auf der lokalen Festplatte speichern:</b> <input type="button" value="Konfiguration speichern"/></p> <p><b>Von der lokalen Festplatte laden:</b> <input type="text"/> <input type="button" value="Browse..."/> <input type="button" value="Konfiguration von Datei wiederherstellen"/></p> <p><b>Auf Werkseinstellungen zurücksetzen:</b> <input type="button" value="Werkseinstellungen wiederherstellen"/> Alle Einstellungen auf die Werkseinstellungen zurücksetzen.</p> <p><b>Starten Sie das Gerät neu:</b> <input type="button" value="Starten Sie das Gerät neu"/></p> <p><b>Sprachpaket löschen:</b> <input type="button" value="Entfernen"/></p>				
FIRMWARE					

DAP-1522	CONFIGURACIÓN	AVANZADO	MANTENIMIENTO	ESTADO	AYUDA
ADMINISTRADOR	<b>PARÁMETROS DEL SISTEMA</b>				<p><b>Sugerencias útiles...</b></p> <p>Una vez que el punto de acceso está configurado como lo desea, puede guardar los parámetros de configuración en un archivo de configuración.</p> <p>Puede que necesite este archivo para poder cargar la configuración más adelante en el caso de que se restablezcan los parámetros predeterminados del punto de acceso.</p> <p>Para guardar la configuración, haga clic en el botón "Guardar configuración".</p> <p>Más información...</p>
HORA	<p>La sección Parámetros del sistema le permite reiniciar el dispositivo o restaurar el punto de acceso a los parámetros predeterminados de fábrica. Al restaurar en la unidad los parámetros predeterminados de fábrica se borrarán todos los parámetros, incluidas las reglas que haya creado.</p> <p>Se pueden guardar los parámetros del sistema actual como un archivo en la unidad de disco duro local. Puede cargarse en la unidad el archivo guardado o cualquier otro archivo de parámetros guardado creado por el dispositivo.</p>				
SISTEMA	<p><b>PARÁMETROS DEL SISTEMA</b></p> <p><b>Guardar en la unidad de disco duro local:</b> <input type="button" value="Guardar configuración"/></p> <p><b>Cargar desde la unidad de disco duro local:</b> <input type="text"/> <input type="button" value="Browse..."/> <input type="button" value="Restablecer la configuración del archivo"/></p> <p><b>Restablecer en los valores predeterminados de fábrica:</b> <input type="button" value="Restablecer valores predeterminados de fábrica"/> Restablecer todos los parámetros en los valores predeterminados de fábrica.</p> <p><b>Reinicie el dispositivo:</b> <input type="button" value="Reiniciar el dispositivo"/></p> <p><b>Borrar paquete de idioma:</b> <input type="button" value="Borrar"/></p>				
FIRMWARE					

DAP-1522	CONFIGURATION	AVANÇÉ	MAINTENANCE	ÉTAT	AIDE
ADMIN	<b>PARAMÈTRES SYSTÈME</b>				<p><b>Conseils utiles...</b></p> <p>Une fois le point d'accès configuré comme vous le souhaitez, vous pouvez enregistrer les paramètres de configuration dans un fichier de configuration.</p> <p>Vous aurez peut-être besoin de ce fichier pour charger votre configuration ultérieurement, en cas de restauration des paramètres par défaut de votre point d'accès.</p> <p>Pour enregistrer la configuration, cliquez sur le bouton "Enregistrer la configuration".</p> <p>Plus...</p>
HEURE	<p>La section Configuration du système vous permet de réinitialiser le périphérique ou de restaurer les paramètres d'usine point d'accès. Restaurer les valeurs d'usine de tous les paramètres efface tous vos paramètres, y compris toutes les règles que vous avez créées.</p> <p>La configuration actuelle du système peut être enregistrée sous forme de fichier sur le disque dur local. Le fichier enregistré ou tout autre fichier de configuration enregistré et créé par le périphérique peut être chargé sur la machine.</p>				
SYSTÈME	<p><b>PARAMÈTRES SYSTÈME</b></p> <p><b>Enregistrer sur le disque dur local:</b> <input type="button" value="Enregistrer la configuration"/></p> <p><b>Charger depuis le disque dur local:</b> <input type="text"/> <input type="button" value="Browse..."/> <input type="button" value="Restaurer la configuration à partir d'un fichier"/></p> <p><b>Restaurer les paramètres par défaut:</b> <input type="button" value="Restaurer les valeurs d'usine"/> Restaurer tous les paramètres sur les valeurs définies à l'usine.</p> <p><b>Réinitialiser le périphérique:</b> <input type="button" value="Réinitialiser le périphérique"/></p> <p><b>Effacer le pack linguistique:</b> <input type="button" value="Effacer"/></p>				
MICROPROGRAMME					

DAP-1522	CONFIGURAZIONE	AVANZATE	MANUTENZIONE	STATO	GUIDA
ADMIN	<b>IMPOSTAZIONI SISTEMA</b>				<p><b>Suggerimenti utili...</b></p> <p>Dopo aver configurato il punto di accesso nel modo desiderato, è possibile salvare le impostazioni in un apposito file di configurazione.</p> <p>Tale file potrebbe essere necessario per caricare la configurazione in un secondo momento qualora venissero ripristinate le impostazioni predefinite del punto di accesso.</p> <p>Per salvare la configurazione, fare clic sul pulsante "Salva configurazione".</p> <p>Altro...</p>
ORA	<p>La sezione Impostazioni sistema consente di riavviare il dispositivo o di ripristinare le impostazioni predefinite del punto di accesso. Il ripristino delle impostazioni predefinite comporta la cancellazione di tutte le impostazioni precedenti, incluse eventuali regole create dall'utente.</p> <p>È possibile salvare le impostazioni di sistema correnti in un file del disco fisso locale. Il file salvato o qualsiasi altro file di impostazioni salvato creato dal dispositivo può quindi essere caricato nell'unità.</p>				
SISTEMA	<p><b>IMPOSTAZIONI SISTEMA</b></p> <p><b>Salva su Disco fisso locale:</b> <input type="button" value="Salva configurazione"/></p> <p><b>Carica da disco fisso locale:</b> <input type="text"/> <input type="button" value="Browse..."/> <input type="button" value="Ripristina configurazione da file"/></p> <p><b>Ripristina impostazioni predefinite:</b> <input type="button" value="Ripristina impostazioni predefinite"/> Ripristina tutte le impostazioni predefinite.</p> <p><b>Riavvio del dispositivo:</b> <input type="button" value="Riavvio del dispositivo"/></p> <p><b>Cancela Language Pack:</b> <input type="button" value="Cancella"/></p>				
FIRMWARE					

# Status

## Device Info

This page displays the current information for the DAP-1522. It will display the LAN and wireless LAN information.

**General:** Displays the access point's time and firmware version.

**LAN:** Displays the MAC address and the private (local) IP settings for the access point.

**Wireless LAN:** Displays the wireless MAC address and your wireless settings such as SSID and Channel.

The screenshot shows the D-Link DAP-1522 web interface. The top navigation bar includes tabs for SETUP, ADVANCED, MAINTENANCE, STATUS (selected), and HELP. The main content area is titled 'DEVICE INFORMATION' and contains the following sections:

- GENERAL:** Firmware Version : 1.20 , 15:25:36 11/21/2008
- LAN:**
  - Connection Type : Static IP
  - MAC Address : 00:1e:58:47:1f:19
  - IP Address : 192.168.0.50
  - Subnet Mask : 255.255.255.0
  - Default Gateway :
- WIRELESS LAN:**
  - Wireless Radio : Enabled
  - Status : disconnected
  - MAC Address : 00:1e:58:47:1f:19
  - Network Name(SSID) : dlink
  - Channel : 1
  - Security Type : Open / Disabled
  - Wi-Fi Protected Setup : Enabled / Not Configured

On the right side, there is a 'Helpful Hints...' section with the text: 'All of your LAN and WLAN connection details are displayed here.' and a 'More...' link.

# Logs

The access point automatically logs (records) events of possible interest in its internal memory. If there isn't enough internal memory for all events, logs of older events are deleted, but logs of the latest events are retained. The Logs option allows you to view the access point logs. You can define what types of events you want to view and the level of the events to view. This access point also has external Syslog Server support so you can send the log files to a computer on your network that is running a Syslog utility.

**What to View:** There are three types of logs that can be viewed: System Activity, Wireless Activity, and Notice. Click on the corresponding check box for the type(s) that you want displayed in the log.

**Enable Remote Log:** Select this check box and enter a Log Server name or IP address to enable the remote log feature.

**Apply Log Settings Now:** Click this button to immediately filter the log results so that only the selected options appear in the Log Details section of this screen.

**Refresh:** Updates the log details on the screen so it displays any recent activity.

**Clear:** This option clears all of the log contents.

**Save Log:** This option will save the access point to a log file on your computer.

**D-Link**

DAP-1522 //

SETUP    ADVANCED    MAINTENANCE    **STATUS**    HELP

DEVICE INFO

LOGS

**LOGS**

View the logs. You can define the event levels to view.

**LOG OPTIONS**

What to View :  System Activity     Wireless Activity     Notice

Enable Remote Log :     Log Server / IP Address :

**LOG DETAILS**

Page 1 of 2

Time	Priority	Message
Uptime 0 day 09:55:44		[Wireless]Initiate Wireless success
Uptime 0 day 09:55:39		[Wireless]Stop Wireless success
Uptime 0 day 09:55:39		[Wireless]Initiate Wireless success
Uptime 0 day 09:55:38		[Wireless]Stop Wireless success
Uptime 0 day 09:32:23		[SYSACT]Web login success from 192.168.0.5
Uptime 0 day 09:32:14		[SYSACT] Device is operating in Bridge mode!
Uptime 0 day 09:32:07		[Wireless]Initiate Wireless success
Uptime 0 day 09:32:05		[Wireless]Stop Wireless success
Uptime 0 day 09:30:05		[SYSACT]Web login success from 192.168.0.5
Uptime 0 day 09:27:59		[SYSACT]Web logout from 192.168.0.5

Helpful Hints..  
Check the log frequently to detect unauthorized network usage.  
More...

# Help

**D-Link**

**DAP-1522** // SETUP ADVANCED MAINTENANCE STATUS HELP

MENU  
SETUP  
ADVANCED  
MAINTENANCE  
STATUS

**SUPPORT MENU**

**Setup Help**

- [Wizard](#)
- [Wireless](#)
- [Network Settings](#)

**Advanced Help**

- [Advanced Wireless](#)
- [QoS](#)
- [Schedule](#)

**Maintenance Help**

- [Admin](#)
- [Time](#)
- [System](#)
- [Firmware](#)

**Status Help**

- [Device Info](#)
- [Logs](#)

Helpful Hints...



# Wireless Security

This section will show you the different levels of security you can use to protect your data from intruders. The DAP-1522 offers the following types of security:

- WPA2 (Wi-Fi Protected Access 2)
- WPA (Wi-Fi Protected Access)
- WEP (Wired Equivalent Privacy)
- WPA2-PSK (Pre-Shared Key)
- WPA-PSK (Pre-Shared Key)

## What is WEP?

WEP stands for Wired Equivalent Privacy. It is based on the IEEE 802.11 standard and uses the RC4 encryption algorithm. WEP provides security by encrypting data over your wireless network so that it is protected as it is transmitted from one wireless device to another.

To gain access to a WEP network, you must know the key. The key is a string of characters that you create. When using WEP, you must determine the level of encryption. The type of encryption determines the key length. 128-bit encryption requires a longer key than 64-bit encryption. Keys are defined by entering in a string in HEX (hexadecimal - using characters 0-9, A-F) or ASCII (American Standard Code for Information Interchange – alphanumeric characters) format. ASCII format is provided so you can enter a string that is easier to remember. The ASCII string is converted to HEX for use over the network. Four keys can be defined so that you can change keys easily.

# What is WPA?

WPA, or Wi-Fi Protected Access, is a Wi-Fi standard that was designed to improve the security features of WEP (Wired Equivalent Privacy).

The 2 major improvements over WEP:

- Improved data encryption through the Temporal Key Integrity Protocol (TKIP). TKIP scrambles the keys using a hashing algorithm and, by adding an integrity-checking feature, ensures that the keys haven't been tampered with. WPA2 is based on 802.11i and uses Advanced Encryption Standard (AES) instead of TKIP.
- User authentication, which is generally missing in WEP, through the extensible authentication protocol (EAP). WEP regulates access to a wireless network based on a computer's hardware-specific MAC address, which is relatively simple to be sniffed out and stolen. EAP is built on a more secure public-key encryption system to ensure that only authorized network users can access the network.

WPA-PSK/WPA2-PSK uses a passphrase or key to authenticate your wireless connection. The key is an alpha-numeric password between 8 and 63 characters long. The password can include symbols (!?\*&\_) and spaces. This key must be the exact same key entered on your wireless bridge or access point.

WPA/WPA2 incorporates user authentication through the Extensible Authentication Protocol (EAP). EAP is built on a more secure public key encryption system to ensure that only authorized network users can access the network.

# Configure WEP in AP Mode

It is recommended to enable encryption on your wireless access point before your wireless network adapters. Please establish wireless connectivity before enabling encryption. Your wireless signal may degrade when enabling encryption due to the added overhead.

1. Log into the web-based configuration by opening a web browser and entering the IP address of the access point (192.168.0.50). Click on **Setup** and then click **Wireless Settings** on the left side.
2. Next to Security Mode in the Wireless Security Mode section, select **WEP**.
3. Next to WEP Key Length in the WEP section, select both the type of input (hexidecimal or ASCII) and the level of encryption (64-bit or 128-bit). Hex - (recommended) Letters A-F and numbers 0-9 are valid.
4. Next to Default WEP Key and the first selection on the drop-down menu, WEP Key 1. Enter a WEP key that you create in the WEP Key value and Verify WEP Key value fields. Make sure you enter this key exactly on all your wireless devices. You may enter up to 4 different keys using the Default WEP Key drop-down menu.
5. Next to *Authentication*, select **Open** or **Shared Key**.
6. Click **Save Settings** at the top of the window to save your settings. If you are configuring the access point with a wireless adapter, you will lose connectivity until you enable WEP on your adapter and enter the same WEP key as you did on the access point.

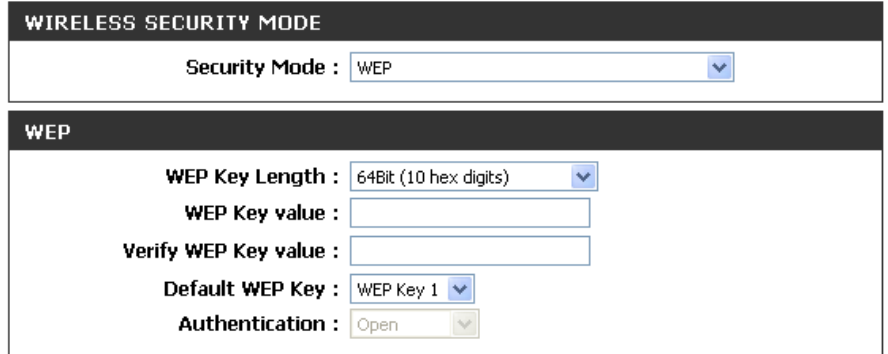

The screenshot displays the 'WIRELESS SECURITY MODE' configuration page. The 'Security Mode' is set to 'WEP'. Below this, the 'WEP' section is expanded, showing the following settings: 'WEP Key Length' is set to '64Bit (10 hex digits)'; 'WEP Key value' and 'Verify WEP Key value' are empty text input fields; 'Default WEP Key' is set to 'WEP Key 1'; and 'Authentication' is set to 'Open'.

# Configure WPA-Personal (AP Mode)

It is recommended to enable encryption on your wireless access point before your wireless network adapters. Please establish wireless connectivity before enabling encryption. Your wireless signal may degrade when enabling encryption due to the added overhead.

1. Log into the web-based configuration by opening a web browser and entering the IP address of the access point (192.168.0.50). Click on Setup and then click Wireless Settings on the left side.
2. Next to *Security Mode in the Wireless Security Mode section*, select **WPA-Personal**.
3. Next to *WPA Mode in the WPA section*, select **Auto (WPA or WPA2)**, **WPA2 Only**, or **WPA Only**. Use **Auto** if you have wireless clients using both WPA and WPA2.
4. Next to Cipher Type, select TKIP, AES, or TKIP and AES.
5. Next to *Group Key Update Interval*, enter the amount of time before the group key used for broadcast and multicast data is changed.
6. Next to the *Pre-Shared Key* section, enter a key in the Passphrase field. The key is entered as a passphrase in ASCII format at both ends of the wireless connection. The passphrase must be between 8-63 characters.
7. Click **Save Settings** at the top of the window to save your settings. If you are configuring the access point with a wireless adapter, you will lose connectivity until you enable WPA-PSK on your adapter and enter the same passphrase as you did on the access point.

The screenshot displays a web-based configuration interface for wireless security. It is divided into three main sections: WIRELESS SECURITY MODE, WPA, and PRE-SHARED KEY. In the WIRELESS SECURITY MODE section, the Security Mode is set to WPA-Personal. The WPA section shows WPA Mode set to Auto (WPA or WPA2), Cipher Type set to TKIP, and Group Key Update Interval set to 1800 seconds. The PRE-SHARED KEY section has a Passphrase field that is currently empty.

WIRELESS SECURITY MODE	
Security Mode :	WPA-Personal

WPA	
WPA Mode :	Auto (WPA or WPA2)
Cipher Type :	TKIP
Group Key Update Interval :	1800 (seconds)

PRE-SHARED KEY	
Passphrase :	

# Configure WPA-Enterprise (AP Mode)

It is recommended to enable encryption on your wireless access point before your wireless network adapters. Please establish wireless connectivity before enabling encryption. Your wireless signal may degrade when enabling encryption due to the added overhead.

1. Log into the web-based configuration by opening a web browser and entering the IP address of the access point (192.168.0.50). Click on **Setup** and then click **Wireless Settings** on the left side.
2. Next to *Security Mode in the Wireless Security Mode section*, select **WPA-Enterprise**.
3. Next to *WPA Mode in the WPA section*, select **Auto (WPA or WPA2)**, **WPA2 Only**, or **WPA Only**. Use Auto if you have wireless clients using both WPA and WPA2.
4. Next to Cipher Type, select **TKIP**, **AES**, or **TKIP and AES**.
5. Next to *Group Key Update Interval*, enter the amount of time before the group key used for broadcast and multicast data is changed.
6. Next to *RADIUS Server IP Address* in the EAP (802.1X) section, enter the IP Address of your RADIUS server.
7. Next to RADIUS Server Port, enter the port you are using with your RADIUS server. 1812 is the default port.
8. Next to *RADIUS Server Shared Secret*, enter the security key.
9. Click **Save Settings** at the top of the window to save your settings.

The screenshot displays the configuration interface for wireless security. It is divided into three main sections: WIRELESS SECURITY MODE, WPA, and EAP (802.1X). In the WIRELESS SECURITY MODE section, the Security Mode is set to WPA-Enterprise. The WPA section shows WPA Mode set to Auto (WPA or WPA2), Cipher Type set to TKIP, and Group Key Update Interval set to 1800 seconds. The EAP (802.1X) section includes fields for RADIUS Server IP Address, RADIUS Server Port (set to 1812), and RADIUS Server Shared Secret.

WIRELESS SECURITY MODE	
Security Mode :	WPA-Enterprise

WPA	
WPA Mode :	Auto (WPA or WPA2)
Cipher Type :	TKIP
Group Key Update Interval :	1800 (seconds)

EAP (802.1X)	
RADIUS Server IP Address :	
RADIUS Server Port :	1812
RADIUS Server Shared Secret :	

# Configure WEP (Bridge Mode)

It is recommended to enable encryption on your wireless access point before your wireless network adapters. Please establish wireless connectivity before enabling encryption. Your wireless signal may degrade when enabling encryption due to the added overhead.

1. Log into the web-based configuration by opening a web browser and entering the IP address of the bridge (192.168.0.50). Click on **Setup** and then click **Wireless Settings**.

2. For **Security Mode** in the *Wireless Security Mode* section, select WEP.

3. Next to WEP Key Length in the WEP section, select both the type of input (hexidecimal or ASCII) and the level of encryption (64-bit or 128-bit). Hex - (recommended) Letters A-F and numbers 0-9 are valid.

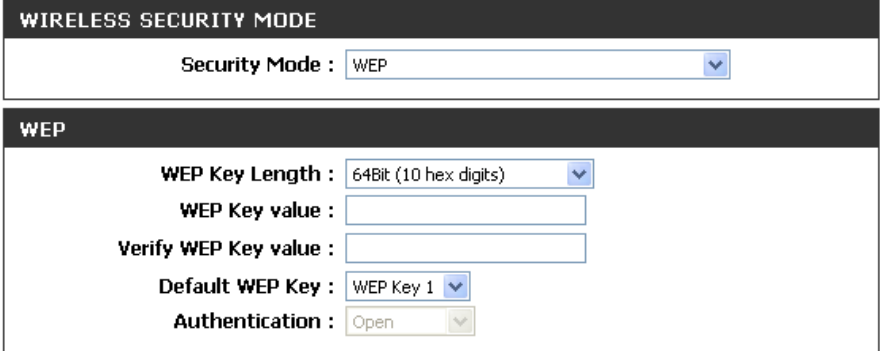

**WIRELESS SECURITY MODE**

Security Mode : WEP

**WEP**

WEP Key Length : 64Bit (10 hex digits)

WEP Key value :

Verify WEP Key value :

Default WEP Key : WEP Key 1

Authentication : Open

4. For the Default WEP Key and the first selection on the drop-down menu, WEP Key 1. Enter a WEP key that you create in the WEP Key value and Verify WEP Key value fields. Make sure you enter this key exactly on all your wireless devices. You may enter up to 4 different keys using the Default WEP Key drop-down menu.

5. For *Authentication*, select **Open** or **Shared Key**.

6. Click **Save Settings** to save your settings. If you are configuring the access point with a wireless adapter, you will lose connectivity until you enable WEP on your adapter and enter the same WEP key as you did on the access point.

# Configure WPA-Personal (Bridge Mode)

It is recommended to enable encryption on your wireless access point before your wireless network adapters. Please establish wireless connectivity before enabling encryption. Your wireless signal may degrade when enabling encryption due to the added overhead.

1. Log into the web-based configuration by opening a web browser and entering the IP address of the bridge (192.168.0.50). Click on **Setup** and then click **Wireless Settings** on the left side.
2. Next to *Security Mode in the Wireless Security Mode section*, select **WPA-Personal**.
3. Next to *WPA Mode in the WPA section*, select **Auto (WPA or WPA2)**, **WPA2 Only**, or **WPA Only**. Use **Auto** if you have wireless clients using both WPA and WPA2.
4. Next to Cipher Type, select **TKIP**, **AES**, or **TKIP and AES**.
5. Next to *Group Key Update Interval*, enter the amount of time before the group key used for broadcast and multicast data is changed.
6. Next to the *Pre-Shared Key section*, enter a key in the Passphrase field. The key is entered as a passphrase in ASCII format at both ends of the wireless connection. The passphrase must be between 8-63 characters.
7. Click **Save Settings** at the top of the window to save your settings. If you are configuring the access point with a wireless adapter, you will lose connectivity until you enable WPA-PSK on your adapter and enter the same passphrase as you did on the access point.

The screenshot displays the configuration interface for wireless security. It is divided into three main sections:

- WIRELESS SECURITY MODE:** A dropdown menu is set to "WPA-Personal".
- WPA:** This section contains three fields:
  - WPA Mode:** A dropdown menu set to "Auto (WPA or WPA2)".
  - Cipher Type:** A dropdown menu set to "TKIP".
  - Group Key Update Interval:** An input field with "(seconds)" to its right.
- PRE-SHARED KEY:** A single input field labeled "Passphrase".

# Connect to a Wireless Network Using Windows® XP

Windows® XP users may use the built-in wireless utility (Zero Configuration Utility). The following instructions are for Service Pack 2 users. If you are using another company's utility or Windows® 2000, please refer to the user manual of your wireless adapter for help with connecting to a wireless network. Most utilities will have a "site survey" option similar to the Windows® XP utility as seen below.

If you receive the **Wireless Networks Detected** bubble, click on the center of the bubble to access the utility.

or

Right-click on the wireless computer icon in your system tray (lower-right corner next to the time). Select **View Available Wireless Networks**.

The utility will display any available wireless networks in your area. Click on a network (displayed using the SSID) and click the **Connect** button.

If you get a good signal, but cannot access the Internet, check you TCP/IP settings for your wireless adapter. Refer to the **Networking Basics** section in this manual for more information.

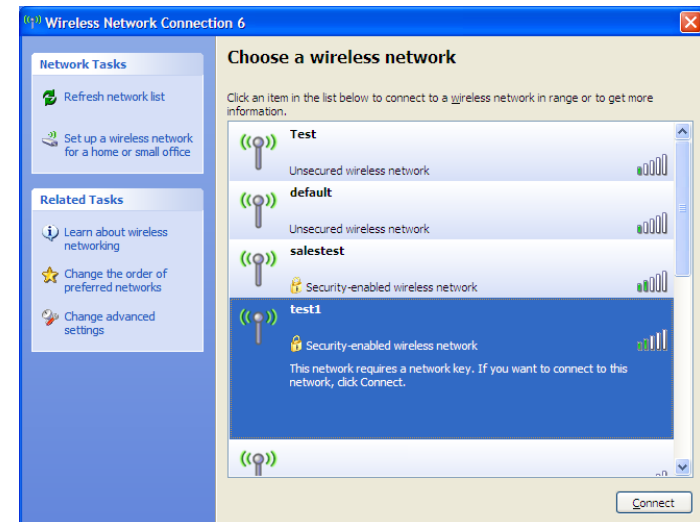
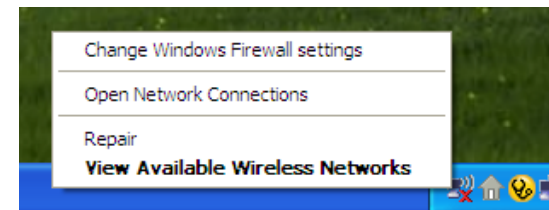
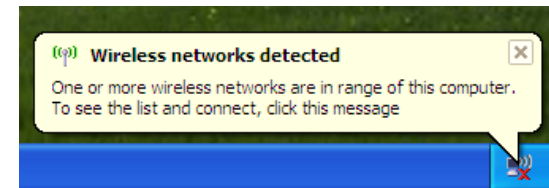



# Configure WEP

It is recommended to enable WEP on your wireless bridge or access point before configuring your wireless adapter. If you are joining an existing network, you will need to know the WEP key being used.

1. Open the Windows® XP Wireless Utility by right-clicking on the wireless computer icon in your system tray (lower-right corner of screen). Select **View Available Wireless Networks**.

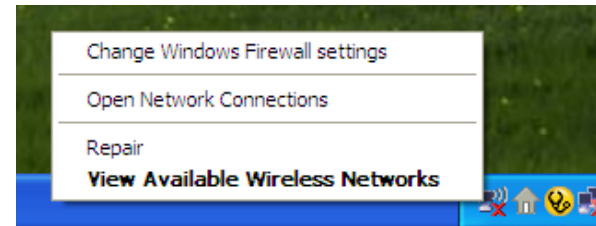

2. Highlight the wireless network (SSID) you would like to connect to and click **Connect**.

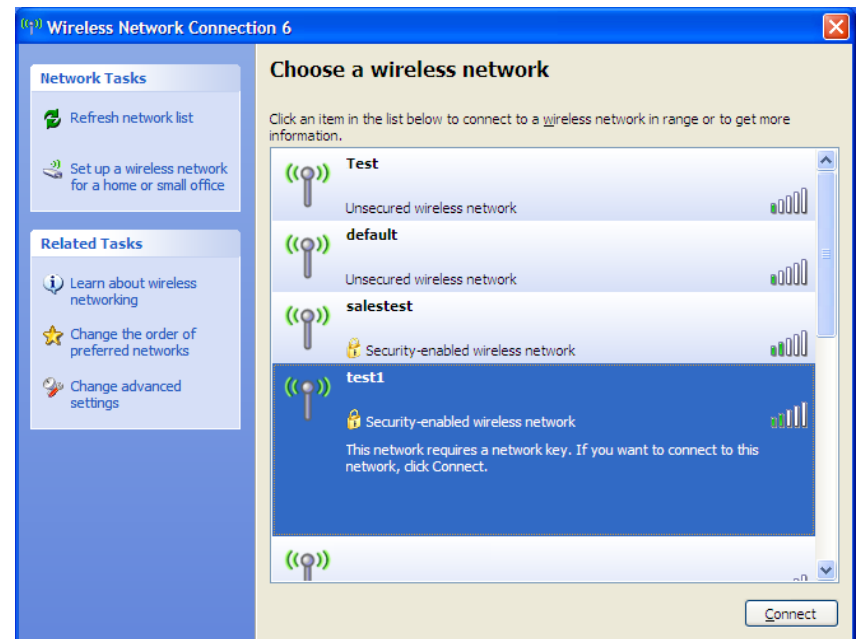

3. The **Wireless Network Connection** box will appear. Enter the same WEP key that is on your access point and click **Connect**.

It may take 20-30 seconds to connect to the wireless network. If the connection fails, please verify that the WEP settings are correct. The WEP key must be exactly the same as on the wireless access point.



# Configure WPA-PSK

It is recommended to enable WEP on your wireless bridge or access point before configuring your wireless adapter. If you are joining an existing network, you will need to know the WEP key being used.

1. Open the Windows® XP Wireless Utility by right-clicking on the wireless computer icon in your system tray (lower-right corner of screen). Select **View Available Wireless Networks**.

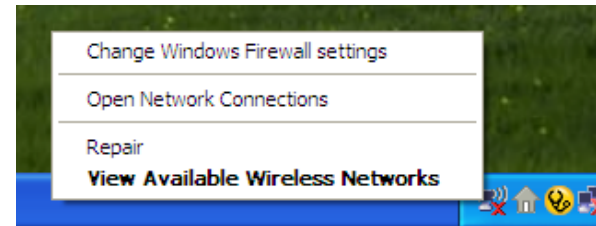

2. Highlight the wireless network (SSID) you would like to connect to and click **Connect**.

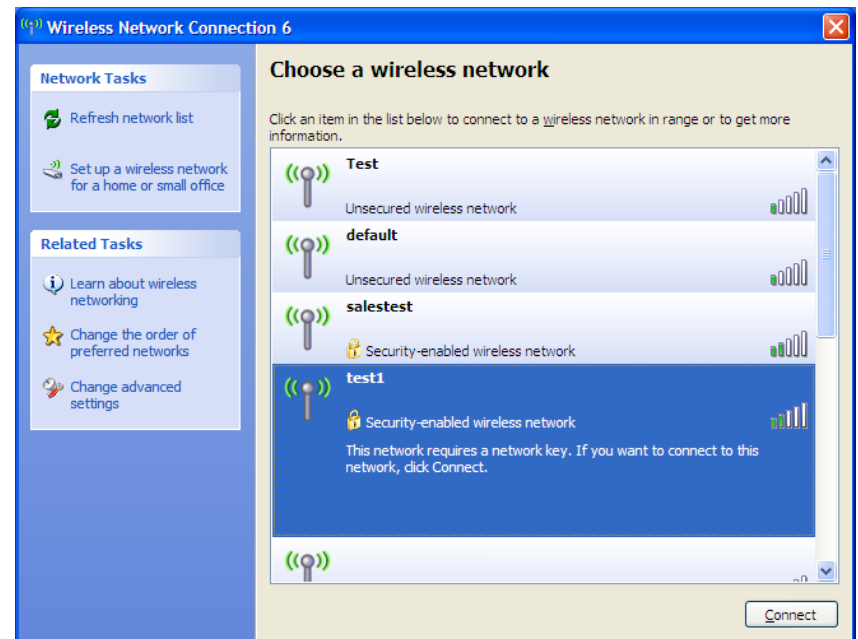

3. The **Wireless Network Connection** box will appear. Enter the WPA-PSK passphrase and click **Connect**.

It may take 20-30 seconds to connect to the wireless network. If the connection fails, please verify that the WPA-PSK settings are correct. The WPA-PSK passphrase must be exactly the same as on the wireless access point.

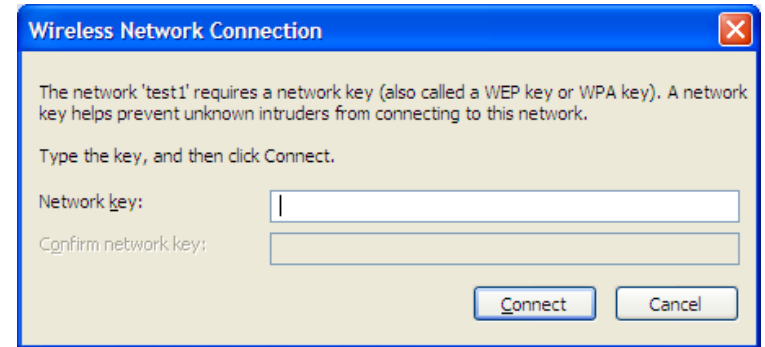

# Connect to a Wireless Network Using Windows® Vista

Windows® Vista users may use the convenient, built-in wireless utility. Follow these instructions:

From the Start menu, go to Control Panel, and then click on **Network and Sharing Center**.

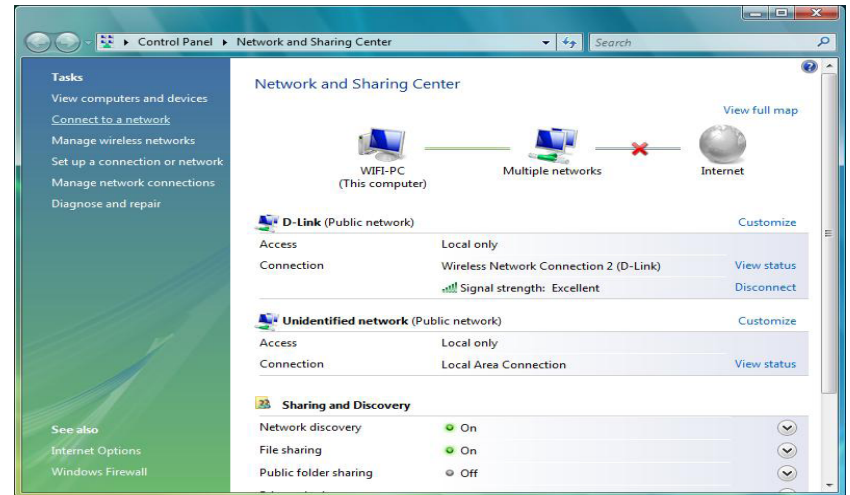

The utility will display any available wireless networks in your area. Click on a network (displayed using the SSID) under **Select a network to connect to** and then click the **Connect** button.

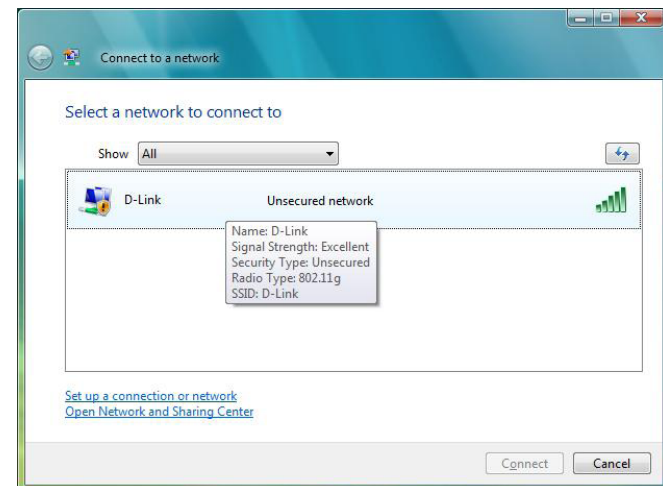

Click **Connect Anyway** to continue.

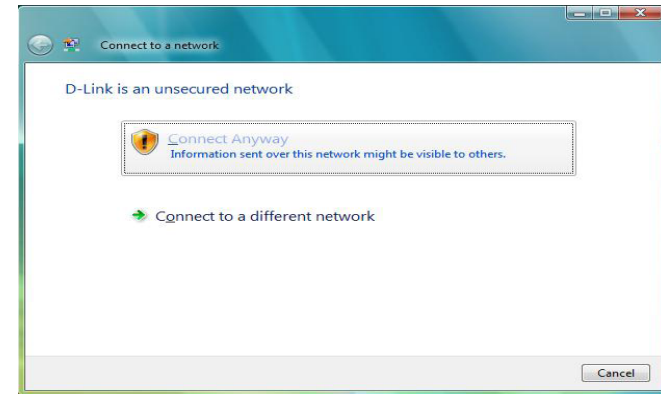

The utility will display the following window to indicate a connection is being made.

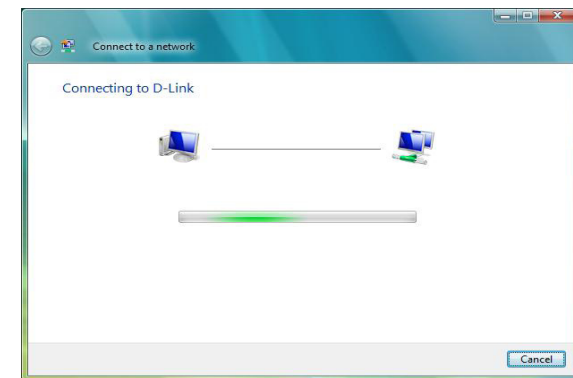

The final window indicates the establishment of a successful connection.

The next two pages display the windows used to connect to either a WEP or a WPA-PSK wireless network.

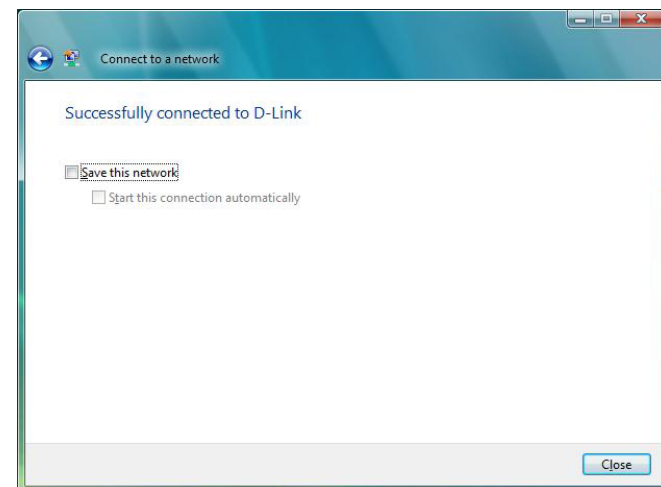

# Configure WEP

It is recommended to enable WEP on your wireless bridge or access point before configuring your wireless adapter. If you are joining an existing network, you will need to know the WEP key being used.

Click on a network (displayed using the SSID) using WEP under Select a network to connect to and then click the **Connect** button.

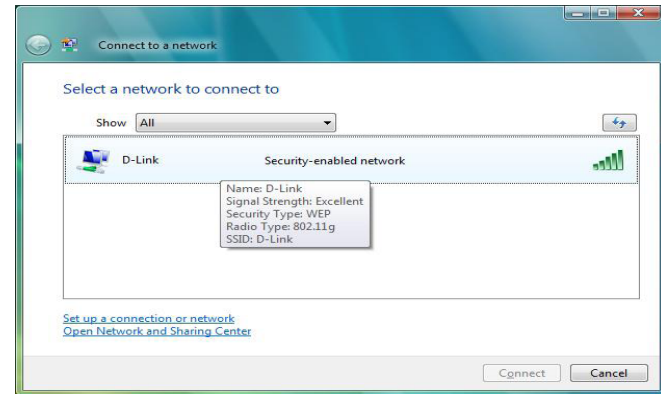

Enter the appropriate security key or passphrase in the field provided and then click the **Connect** button.

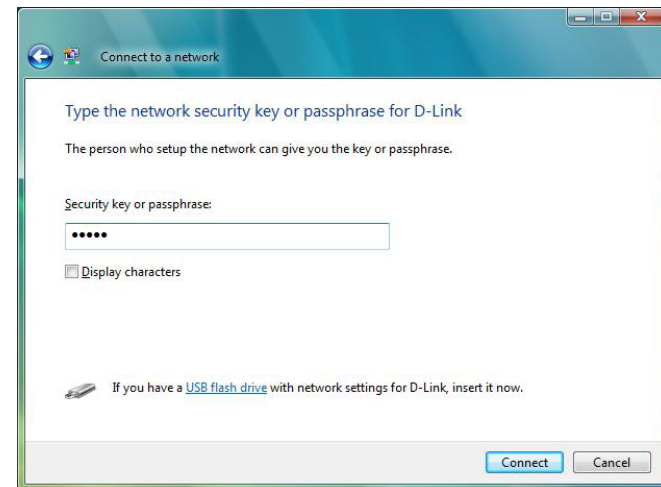

# Configure WPA-PSK

It is recommended to enable WEP on your wireless bridge or access point before configuring your wireless adapter. If you are joining an existing network, you will need to know the WEP key being used.

Click on a network (displayed using the SSID) using WPA-PSK under Select a network to connect to and then click the **Connect** button.

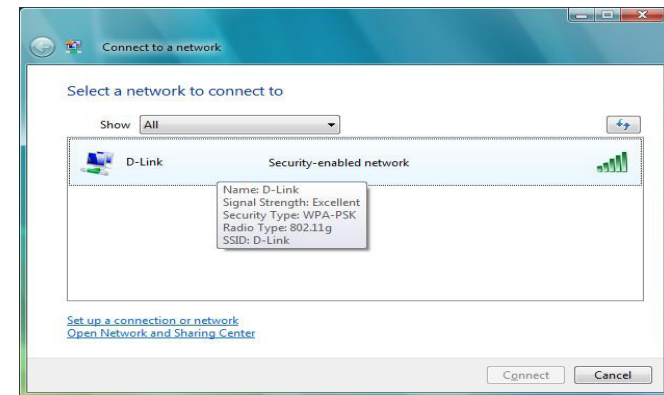

Enter the appropriate security key or passphrase in the field provided and then click the **Connect** button.

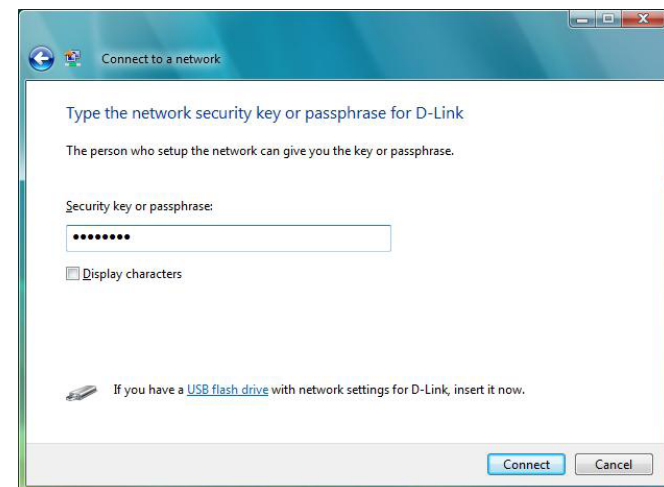



# Troubleshooting

This chapter provides solutions to problems that can occur during the installation and operation of the DAP-1522. Read the following descriptions if you are having problems. (The examples below are illustrated in Windows® XP. If you have a different operating system, the screenshots on your computer will look similar to the following examples.)

## 1. Why can't I access the web-based configuration utility?

When entering the IP address of the D-Link access point (192.168.0.50 for example), you are not connecting to a website on the Internet or have to be connected to the Internet. The device has the utility built-in to a ROM chip in the device itself. Your computer must be on the same IP subnet to connect to the web-based utility.

- Make sure you have an updated Java-enabled web browser. We recommend the following:
  - Internet Explorer 7.0 or higher
  - Firefox 3.0 or higher
- Verify physical connectivity by checking for solid link lights on the device. If you do not get a solid link light, try using a different cable or connect to a different port on the device if possible. If the computer is turned off, the link light may not be on.
- Disable any internet security software running on the computer. Software firewalls such as Zone Alarm, Black Ice, Sygate, Norton Personal Firewall, and Windows® XP firewall may block access to the configuration pages. Check the help files included with your firewall software for more information on disabling or configuring it.

- Configure your Internet settings:
  - Go to **Start > Settings > Control Panel**. Double-click the **Internet Options** icon. From the Security tab, click the button to restore the settings to their defaults.
  - Click the Connection tab and set the dial-up option to Never Dial a Connection. Click the LAN Settings button. Make sure nothing is checked. Click OK.
  - Go to the Advanced tab and click the button to restore these settings to their defaults. Click OK three times.
  - Close your web browser (if open) and open it.
- Access the web management. Open your web browser and enter the IP address of your D-Link access point in the address bar. This should open the login page for your the web management.
- If you still cannot access the configuration, unplug the power to the access point for 10 seconds and plug back in. Wait about 30 seconds and try accessing the configuration. If you have multiple computers, try connecting using a different computer.

## 2. What can I do if I forgot my password?

If you forgot your password, you must reset your access point. Unfortunately this process will change all your settings back to the factory defaults.

To reset the access point, locate the reset button (hole) on the rear panel of the unit. With the access point powered on, use a paperclip to hold the button down for 10 seconds. Release the button and the access point will go through its reboot process. Wait about 30 seconds to access the access point. The default IP address is 192.168.0.50. When logging in, the username is admin and leave the password box empty.

### 3. Why can't I connect to certain sites or send and receive emails when connecting through my access point?

If you are having a problem sending or receiving email, or connecting to secure sites such as eBay, banking sites, and Hotmail, we suggest lowering the MTU in increments of ten (Ex. 1492, 1482, 1472, etc).

**Note: AOL DSL+ users must use MTU of 1400.**

To find the proper MTU Size, you'll have to do a special ping of the destination you're trying to go to. A destination could be another computer, or a URL.

- Click on Start and then click Run.
- Windows® 95, 98, and Me users type in command (Windows® NT, 2000, and XP users type in cmd) and press Enter (or click OK).
- Once the window opens, you'll need to do a special ping. Use the following syntax:

```
ping [url] [-f] [-l] [MTU value]
```

Example: ping yahoo.com -f -l 1472

```
C:\>ping yahoo.com -f -l 1482
Pinging yahoo.com [66.94.234.13] with 1482 bytes of data:
Packet needs to be fragmented but DF set.
Packet needs to be fragmented but DF set.
Packet needs to be fragmented but DF set.
Packet needs to be fragmented but DF set.

Ping statistics for 66.94.234.13:
    Packets: Sent = 4, Received = 0, Lost = 4 (100% loss),
    Approximate round trip times in milli-seconds:
        Minimum = 0ms, Maximum = 0ms, Average = 0ms

C:\>ping yahoo.com -f -l 1472
Pinging yahoo.com [66.94.234.13] with 1472 bytes of data:
Reply from 66.94.234.13: bytes=1472 time=93ms TTL=52
Reply from 66.94.234.13: bytes=1472 time=109ms TTL=52
Reply from 66.94.234.13: bytes=1472 time=125ms TTL=52
Reply from 66.94.234.13: bytes=1472 time=203ms TTL=52

Ping statistics for 66.94.234.13:
    Packets: Sent = 4, Received = 4, Lost = 0 (0% loss),
    Approximate round trip times in milli-seconds:
        Minimum = 93ms, Maximum = 203ms, Average = 132ms

C:\>
```

You should start at 1472 and work your way down by 10 each time. Once you get a reply, go up by 2 until you get a fragmented packet. Take that value and add 28 to the value to account for the various TCP/IP headers. For example, lets say that 1452 was the proper value, the actual MTU size would be 1480, which is the optimum for the network we're working with ( $1452+28=1480$ ).

Once you find your MTU, you can now configure your access point with the proper MTU size.

To change the MTU rate on your access point follow the steps below:

- Open your browser, enter the IP address of your access point (192.168.0.50) and click **OK**.
- Enter your username (admin) and password (blank by default). Click **OK** to enter the web configuration page for the device.
- Click on **Setup** and then click **Manual Configure**.
- To change the MTU enter the number in the MTU field and click **Save Settings** to save your settings.
- Test your email. If changing the MTU does not resolve the problem, continue changing the MTU in increments of ten.

# Wireless Basics

D-Link wireless products are based on industry standards to provide easy-to-use and compatible high-speed wireless connectivity within your home, business or public access wireless networks. Strictly adhering to the IEEE standard, the D-Link wireless family of products will allow you to securely access the data you want, when and where you want it. You will be able to enjoy the freedom that wireless networking delivers.

A wireless local area network (WLAN) is a cellular computer network that transmits and receives data with radio signals instead of wires. Wireless LANs are used increasingly in both home and office environments, and public areas such as airports, coffee shops and universities. Innovative ways to utilize WLAN technology are helping people to work and communicate more efficiently. Increased mobility and the absence of cabling and other fixed infrastructure have proven to be beneficial for many users.

Wireless users can use the same applications they use on a wired network. Wireless adapter cards used on laptop and desktop systems support the same protocols as Ethernet adapter cards.

Under many circumstances, it may be desirable for mobile network devices to link to a conventional Ethernet LAN in order to use servers, printers or an Internet connection supplied through the wired LAN. A Wireless Access point is a device used to provide this link.

## **What is Wireless?**

Wireless or Wi-Fi technology is another way of connecting your computer to the network without using wires. Wi-Fi uses radio frequency to connect wirelessly, so you have the freedom to connect computers anywhere in your home or office.

D-Link is the worldwide leader and award winning designer, developer, and manufacturer of networking products. D-Link delivers the performance you need at a price you can afford. D-Link has all the products you need to build your network.

## **How does wireless work?**

Wireless works similar to how cordless phone work, through radio signals to transmit data from one point A to point B. But wireless technology has restrictions as to how you can access the network. You must be within the wireless network range area to be able to connect your computer. There are two different types of wireless networks Wireless Local Area Network (WLAN), and Wireless Personal Area Network (WPAN).

## **Wireless Local Area Network (WLAN)**

In a wireless local area network, a device called an Access Point (AP) connects computers to the network. The access point has a small antenna attached to it, which allows it to transmit data back and forth over radio signals. With an indoor access point as seen in the picture, the signal can travel up to 300 feet. With an outdoor access point the signal can reach out up to 30 miles to serve places like manufacturing plants, industrial locations, college and high school campuses, airports, golf courses, and many other outdoor venues.

## **Wireless Personal Area Network (WPAN)**

Bluetooth is the industry standard wireless technology used for WPAN. Bluetooth devices in WPAN operate in a range up to 30 feet away.

Compared to WLAN the speed and wireless operation range are both less than WLAN, but in return it doesn't use nearly as much power which makes it ideal for personal devices, such as mobile phones, PDAs, headphones, laptops, speakers, and other devices that operate on batteries.

### **Who uses wireless?**

Wireless technology has become so popular in recent years that almost everyone is using it, whether it's for home, office, business, D-Link has a wireless solution for it.

#### **Home**

- Gives everyone at home broadband access
- Surf the web, check email, instant message, etc.
- Gets rid of the cables around the house
- Simple and easy to use

#### **Small Office and Home Office**

- Stay on top of everything at home as you would at office
- Remotely access your office network from home
- Share Internet connection and printer with multiple computers
- No need to dedicate office space

## **Where is wireless used?**

Wireless technology is expanding everywhere not just at home or office. People like the freedom of mobility and it's becoming so popular that more and more public facilities now provide wireless access to attract people. The wireless connection in public places is usually called "hotspots".

Using a D-Link Cardbus Adapter with your laptop, you can access the hotspot to connect to Internet from remote locations like: Airports, Hotels, Coffee Shops, Libraries, Restaurants, and Convention Centers.

Wireless network is easy to setup, but if you're installing it for the first time it could be quite a task not knowing where to start. That's why we've put together a few setup steps and tips to help you through the process of setting up a wireless network.

## **Tips**

Here are a few things to keep in mind, when you install a wireless network.

### **Centralize your access point or Access Point**

Make sure you place the bridge/access point in a centralized location within your network for the best performance. Try to place the bridge/access point as high as possible in the room, so the signal gets dispersed throughout your home. If you have a two-story home, you may need a repeater to boost the signal to extend the range.

### **Eliminate Interference**

Place home appliances such as cordless telephones, microwaves, wireless speakers, and televisions as far away as possible from the bridge/access point. This would significantly reduce any interference that the appliances might cause since they operate on same frequency.



## Security

Don't let your next-door neighbors or intruders connect to your wireless network. Secure your wireless network by turning on the WPA or WEP security feature on the access point. Refer to product manual for detail information on how to set it up.

# Wireless Modes

There are basically two modes of networking:

- **Infrastructure** – All wireless clients will connect to an access point or wireless bridge.
- **Ad-Hoc** – Directly connecting to another computer, for peer-to-peer communication, using wireless network adapters on each computer, such as two or more wireless network Cardbus adapters.

An Infrastructure network contains an Access Point or wireless bridge. All the wireless devices, or clients, will connect to the wireless bridge or access point.

An Ad-Hoc network contains only clients, such as laptops with wireless cardbus adapters. All the adapters must be in Ad-Hoc mode to communicate.

# Networking Basics

## Check your IP address

After you install your new D-Link adapter, by default, the TCP/IP settings should be set to obtain an IP address from a DHCP server (i.e. wireless router) automatically. To verify your IP address, please follow the steps below.

Click on **Start > Run**. In the run box type **cmd** and click **OK**.

At the prompt, type **ipconfig** and press **Enter**.

This will display the IP address, subnet mask, and the default gateway of your adapter.

If the address is 0.0.0.0, check your adapter installation, security settings, and the settings on your access point. Some firewall software programs may block a DHCP request on newly installed adapters.

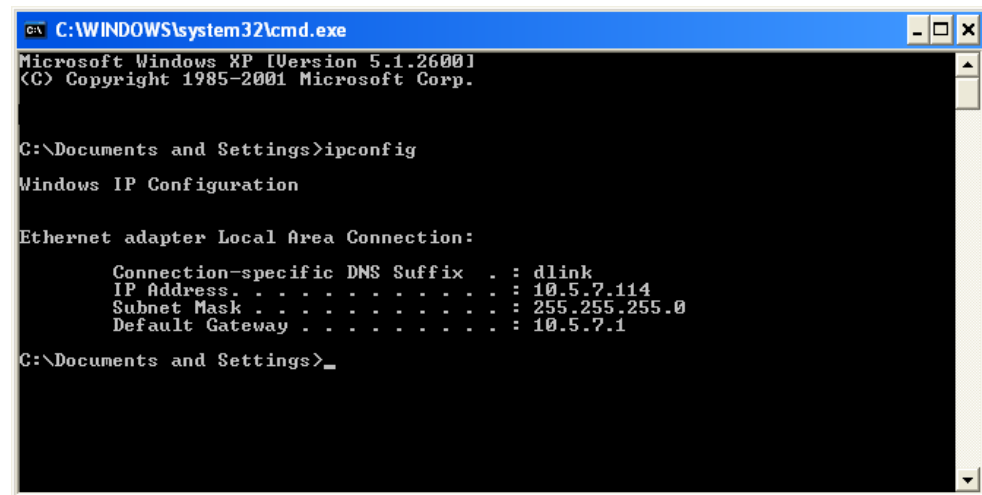

```
C:\WINDOWS\system32\cmd.exe
Microsoft Windows XP [Version 5.1.2600]
(C) Copyright 1985-2001 Microsoft Corp.

C:\Documents and Settings>ipconfig

Windows IP Configuration

Ethernet adapter Local Area Connection:

    Connection-specific DNS Suffix  . : dlink
    IP Address . . . . . : 10.5.7.114
    Subnet Mask . . . . . : 255.255.255.0
    Default Gateway . . . . . : 10.5.7.1

C:\Documents and Settings>_
```

If you are connecting to a wireless network at a hotspot (e.g. hotel, coffee shop, airport), please contact an employee or administrator to verify their wireless network settings.

## Statically Assign an IP address

If you are not using a DHCP capable gateway/access point, or you need to assign a static IP address, please follow the steps below:

### Step 1

Windows® XP - Click on **Start > Control Panel > Network Connections**.

Windows® 2000 - From the desktop, right-click **My Network Places > Properties**.

### Step 2

Right-click on the Local Area Connection which represents your D-Link network adapter and select **Properties**.

### Step 3

Highlight **Internet Protocol (TCP/IP)** and click **Properties**.

### Step 4

Click **Use the following IP address** and enter an IP address that is on the same subnet as your network or the LAN IP address on your access point.

Example: If the access point's LAN IP address is 192.168.0.1, make your IP address 192.168.0.X where X is a number between 2 and 99. Make sure that the number you choose is not in use on the network. Set Default Gateway the same as the LAN IP address of your access point (192.168.0.1).

Set Primary DNS the same as the LAN IP address of your router (192.168.0.1). The Secondary DNS is not needed or you may enter a DNS server from your ISP.

### Step 5

Click **OK** twice to save your settings.

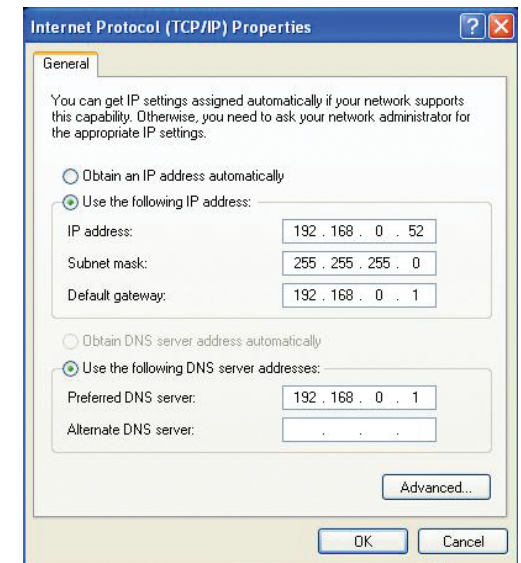

# Technical Specifications

## Standards

- IEEE 802.11n
- IEEE 802.11a
- IEEE 802.11g
- IEEE 802.11b
- IEEE 802.3
- IEEE 802.3u

## Security

- WPA-Personal
- WPA2-Personal
- WPA-Enterprise
- WPA2-Enterprise
- 64/128-bit WEP

## Wireless Signal Rates<sup>1</sup>

- 300Mbps
- 54Mbps
- 36Mbps
- 18Mbps
- 11Mbps
- 6Mbps
- 2Mbps
- 108Mbps
- 48Mbps
- 24Mbps
- 12Mbps
- 9Mbps
- 5.5Mbps
- 1Mbps

## Maximum Operating Voltage

- 3.3V

## Maximum Operating Current

- 1435 mA

## Modulation

- 11b: DQPSK, DBPSK and CCK
- 11a/g: BPSK, QPSK, 16QAM, 64QAM, OFDM
- 11n: BPSK, QPSK, 16QAM, 64QAM, OFDM, MCS

## Frequency Range<sup>2</sup>

- 2.4GHz to 2.483GHz
- 5.15GHz~5.825GHz<sup>3</sup>

## LEDs

- Power
- AP
- Bridge
- LAN

## Operating Temperature

- 32°F to 104°F ( 0°C to 40°C)

## Humidity

- 90% maximum (non-condensing)

## Safety & Emissions

- FCC
- IC
- CSA
- CE
- C-Tick

## Dimensions

- L = 5.75 inches
- W = 4.5 inches
- H = 1.25 inches

<sup>1</sup>Maximum wireless signal rate derived from IEEE Standard 802.11g, 802.11a and Draft 802.11n specifications. Actual data throughput will vary. Network conditions and environmental factors, including volume of network traffic, building materials and construction, and network overhead, lower actual data throughput rate. Environmental conditions will adversely affect wireless signal range.

<sup>2</sup>Range varies depending on country's regulation.

<sup>3</sup>The DAP-1522 doesn't include 5.25-5.35GHz & 5.47~5.725GHz.